

# **TENDER**

FOR

**FABRICATION, SUPPLY & INSTALLATION OF WOODEN EXHIBIT  
CABINETS FOR GEO SCIENCE MUSEUM PH-2, GWALIOR**



## **Creative Museum Designers**

*(A Section 8 Company Guaranteed by National Council of Science Museums)*

*Govt. of India*

*33 Block- GN, Sector-V, Bidhannagar,*

*Kolkata-700 091*

## **Creative Museum Designers**

*(A Section 8 Company Guaranteed by National Council of Science Museums)*

*Govt. of India*

*33 Block- GN, Sector-V, Bidhannagar,*

*Kolkata-700 091*

### **NOTICE INVITING TENDER**

**Tender No. CMD- 007.12.52.1(WORKS)/23-24/18**

**Creative Museum Designers** invites sealed tenders under two-bid system from reputed and experienced agencies for the **FABRICATION, SUPPLY & INSTALLATION OF WOODEN EXHIBIT CABINETS FOR GEO SCIENCE MUSEUM PH-2, GWALIOR.**

Interested agencies are required to submit the technical and financial bids separately. The bids in Sealed **Part-I/Envelope-I** containing “**Technical Bid**” (**Part-I**) and Sealed **Part-II/Envelope-II** containing “**Financial Bid**” ( **Part-II** ) should be placed in a third sealed cover superscribing “**FABRICATION, SUPPLY & INSTALLATION OF WOODEN EXHIBIT CABINETS FOR GEO SCIENCE MUSEUM PH-2, GWALIOR**” along with the Tender No. CMD-007.12.52.1(WORKS)/23-24/18 and should reach CMD at the above address by 03.00 PM on or before **10<sup>th</sup> October, 2023**. The technical bids shall be opened on the same day at 04:00 PM at CMD.

The tender document containing eligibility criteria, the scope of work, terms & conditions and the draft agreement can be downloaded from CMD’s website. **The bid security (EMD) of ₹60,000.00 (Rupees Sixty Thousand only) should be paid by an acceptable mode of payment as prescribed in the Tender Document in favour of Creative Museum Designers, payable at Kolkata.**

The bid shall remain valid for 120 days from the date of opening of the Technical bid. Any future clarification and /or corrigendum(s) shall be communicated through the tender section on the CMD’s website <http://cmdncsm.in/tenders>.

Note: This notice is a part of the Tender Document.

**PROJECT INTRODUCTION: -**

CMD is entrusted with developing the GSI PH-2 Museum for Gwalior. CMD has already developed one thematic gallery based on the Geo Science Principle and now CMD is going to initiate the next phase of Gallery work. The work consisting of FABRICATION, SUPPLY & INSTALLATION OF WOODEN EXHIBIT CABINETS at Gwalior Site.

**SCOPE OF WORK: -**

Fabrication, supply & installation of wooden exhibit cabinets for GEO SCIENCE MUSEUM Ph-2, Gwalior as per drawing with specified materials and excellent finish quality.

1. The place of work will be **GEO-SCIENCE MUSEUM GWALIOR , OLD VICTORIA MARKET, JIWAJI CHOWK, GWALIOR, MADHYA PRADESH 474001.**
2. The estimated cost of the work is approximately **Rs. 26 Lakh/- (Rupees Twenty Six Lakhs only).**
3. Time for carrying out the work will be **45 days + 10 days** of mobilization time from the date of award of the work.
4. Tenders will be issued between **10.00 AM and 5.00 PM** on all working days from **19-th September, 2023 till 10-th October, 2023** from **CMD Office, Kolkata** and same can be also downloaded from <http://cmdncsm.in/tenders> and/or [www.ncsm.gov.in](http://www.ncsm.gov.in) website. Duly filled in tenders will be received up to **3.00 PM on 10 th October, 2023**, Part-I of the tender will be opened on the same day i.e. on **10th October, 2023, at 4.00 p.m.** in presence of available Tenderers/bidders. Tenderers may note that opening of tenders in their presence or in the presence of their authorized representatives is not obligatory on the part of the consideration of the Company. In case the tenderers or their authorized representatives are not present, tenders will be opened as per rules and on the scheduled date and time unless it is notified otherwise by the company. The Company reserves the right to alter the dates of issue, receipt and or opening of tenders etc. if necessary. Tenders received after the due date and time shall not be accepted and will be rejected straightway without any further reference. The date for opening of Part-II containing Financial Bid will be intimated to the qualified tenderers separately.

5. **EVALUATION CRITERIA:**

The evaluation will be based on the main work only. The contract price shall be arrived at by adding up the prices of all the enclaves ( 1 – 7) of the work in the **FINANCIAL BID, ( PRICE OFFER FORM IN ANNEX.III)** and a single contract will be awarded to the tenderer who offers lowest contract price [i.e. lowest sum total ( inclusive of GST) of all the enclaves ( 1 – 7) of the work in the **FINANCIAL BID**]. *The work, being integrated in nature, cannot be split under any circumstances.*

**BIDDER QUALIFICATION CRITERIA:**

Bidders intending to participate shall fulfil the following qualification criteria:

**A. Techno Commercial Criteria:**

The bidders should have experience in executing similar work i.e. fabrication, supply &

installation of wooden exhibit cabinets or wooden exhibit-related work in Govt./Semi Govt./Public Sector/ Corporate offices, of having minimum contract value as indicated below in the last 3(three) years reckoned from the due date for submission of the bid.

- a) One contract having minimum value of 80% of the total estimated project value of the tender i.e. Rs.20.80 Lakhs.
- b) Two contracts each of minimum value of 50% of the total estimated project value of the tender i.e Rs.13 Lakhs.
- c) Three contracts each of minimum value of 40% of the total estimated project value of the tender i.e. Rs.10.40 Lakhs.

**B. Financial Criteria:**

- a) The bidder must have PAN issued by the Income Tax Department of India.
- b) Bidder should have GST, PF & ESI registration with the concerned authorities.
- c) Average Annual Turnover for the last 3 (Three) years must be equal to or greater than Rs. 26 Lakhs.

6. The tenderers should quote their rates in figures as well as in words. The evaluation will be based on the main work only.
7. Offers should be submitted in sealed covers as indicated below in clause no.16, along with the **Earnest money deposit of ₹ 60,000.00/- (Rupees Sixty Thousand Only) by way of crossed Demand Draft/Pay Order/ Banker's Cheque / NEFT drawn on any Nationalized Bank / Scheduled Commercial Bank of India and payable at “Kolkata”. in favour of “Creative Museum Designers”.**

<b><u>Details of Bankers:</u></b>		
<b>Bank Name:</b>	<b>:</b>	<b>INDIAN OVERSEAS BANK</b>
<b>Beneficiary Name:</b>	<b>:</b>	<b>CREATIVE MUSEUM DESIGNERS</b>
<b>Bank Address:</b>	<b>:</b>	<b>Indian Overseas Bank, GN 34/2, Sector - V, II Studio, Saltlake, Kolkata - 700091, West Bengal, India</b>
<b>A/c No.:</b>	<b>:</b>	<b>164201000001214</b>
<b>IFSC Code:</b>	<b>:</b>	<b>IOBA0001642</b>

**Demand Draft/Pay Order/ Banker's Cheque / Documents confirming NEFT**(amount must be credited to CMD’s account as mentioned above on or before the last date of submission i.e. **10.10.2023 up to 03.00 PM**) for the Earnest Money Deposit. For NEFT Transfer supporting receipt must be given. EMD of unsuccessful bidder/tenders shall be returned after finalisation of the Tender, without any interest. Earnest Money Deposit in respect of the successful tenderer will be retained with

the Creative Museum Designers, Kolkata as per terms of clause No. 08 of GTC of this document. If the successful tenderer fails to execute the order strictly as per the drawings and specifications provided by the Creative Museum Designers, Kolkata, in full or in part within the stipulated period of time in the work order, or fails to accept the work after placement of the order or fails to take up the work within stipulated time as mentioned in the clause No.2 of GTC, the Earnest Money Deposit retained with the Creative Museum Designers shall be forfeited forthwith after the cancellation of the concerned Work order. No interest will be paid on the Earnest Money Deposit by Creative Museum Designers, Kolkata.

8. Tenders which do not fulfil any of the above conditions or are incomplete in any respect are liable for summary rejection.
9. The company does not bind itself to accept the lowest tender and reserves to itself the right to reject or partially accept any or all the tenders, tendered items or schedules received without assigning any reason whatsoever.
10. Canvassing in connection with tenders is strictly prohibited and the tenders submitted by the tenderers who resort to canvassing will be liable for rejection on that ground alone.
11. Tenders incorporating additional conditions are liable to be rejected.
12. The tenderers must declare in writing that neither they nor any of them is in anyway related to any officer in the Creative Museum Designers, Kolkata, or any of its constituent units.
13. All taxes and duties on materials, freight & transit Insurance F.O.R. site in respect of this contract will be payable by the successful tenders. Nothing extra will be payable for the increase in such taxes or duties even if imposed or levied either before or after the tenders are opened or during the currency of the contract.
14. Before submitting the tender, the tenderer shall examine all specifications, drawings, and conditions of the contract and inspect the site if necessary.
15. Tender must be submitted in two separate sealed covers marked PART – I (Technical Bid) and PART – II (Financial Bid). These two envelopes shall be put inside a third envelope superscribing “**FABRICATION, SUPPLY & INSTALLATION OF WOODEN EXHIBIT CABINETS FOR GEO SCIENCE MUSEUM PH-2, GWALIOR.**” Bids of only the qualified tenderers/bidders shall be opened.
16. The contents of PART – I and PART – II will be as follows:  
**PART – I**  
This sealed cover shall contain: -
  - a. Self-attested copies of the following documents alongwith the tender documents:
    - a) Valid Labour Licence
    - b) Trade Licence
    - c) Details of works of similar nature carried out in Central / State Govt. bodies / Department /PSUs / Autonomous bodies/industries/factories or other similar organisations. in the last 3 financial years.

- d) Copies of Balance Sheet and Profit & Loss A/c of previous three financial years duly certified by CA.
  - e) List of Arbitration cases (if any)
  - f) Copies of GST and PAN.
  - g) Details of managerial, supervisory and other staff if available.
  - h) Copy of Last 3 years' ITR.
- b. Certificates provided for the works detailed in 'a.(c)' above shall clearly indicate the scope and nature of work undertaken and the value of various components of work as executed, in order to confirm conformity with the defined similar works.
- c. Forwarding letter clearly indicating the documents attached therein. The tenderer shall clearly state in the forwarding letter that **they have not put any extra conditions in the offer form in PART - II.**
- d. "General Terms and Conditions", "Technical specification for **FABRICATION, SUPPLY & INSTALLATION OF WOODEN EXHIBIT CABINETS FOR GEO SCIENCE MUSEUM PH-2, GWALIOR.**" and "Declarations" duly signed by the tenderer on all the pages along with official seal.
- e. **A Draft / Pay order/ Banker's Cheque/NEFT for an amount of ₹60,000.00/- as Earnest Money Deposit.**
- f. Two Declarations (1 and 2) duly signed by the tenderer along with the official seal. (format provided)
- g. Tenderer/bidder shall submit details as per **Annexure-I** and **Annexure-II** along with the Technical Bid.
- h. Additional/Counter Terms & conditions will not be accepted and also any additions/deletions or changes in our format will not be allowed.
- i. **The sealed tender should be dropped in the Tender Box kept on the 4<sup>th</sup> floor of Creative Museum Designers, NCSM Campus, Building-II, 33, Block-GN, Sector-V, Bidhannagar, Kolkata- 700 091 on or before 3 PM on 10<sup>th</sup> October 2023.**
- j. **Tenders received late (including postal delay)/ in open condition/ without EMD/ not meeting the tender condition incomplete in any respect are liable to be rejected.**
- k. **Bidders are advised to study carefully the tender documents and the conditions before quoting their bid. All the pages of the tender document should be signed and stamped by the bidder as a token of acceptance. An incomplete bid in any respect is liable to be rejected.**
- l. In exceptional circumstances, prior to the expiry of the bid validity period, CMD may request tenderers to extend the period of validity of their bids. The request and the responses shall be made in writing.
- m. The technical bids will be evaluated first. The Financial bids of only those agencies whose credentials are found to be acceptable shall be opened.

## **PART – II**

- a. Part II sealed cover shall contain the “ Price Offer Form” as per **Annexure-III** in the prescribed format, duly filled in and signed with stamp and date on all its pages. The cover will have to be superscribed with the name of the work. No extra conditions whatsoever shall be put in Part II. If any such additional conditions are found in Part II, it will not be taken into consideration and the tender will be rejected.
  - b. The financial bids (Part-II) of only the eligible tenderers shall be opened after the evaluation of technical bids (Part-I).
  - c. The rates should be indicated both in words and figures. In case of discrepancy between the figure(number) and words, the rates given in words only will be taken as authenticate and no further clarification will be sought from the bidder.
  - d. All the pages of the Financial Bid should be signed and stamped by the bidder. An incomplete bid in any respect is liable to be rejected.
  - e. In exceptional circumstances, prior to the expiry of the bid validity period, CMD may request tenderers to extend the period of validity of their bids. The request and the responses shall be made in writing.
  - f. The date for opening Part-II containing Financial Bid will be intimated to the qualified tenderers separately.
17. For the purpose of opening the tenders, it is clarified that only the sealed envelope marked Part I will be opened first. After the opening authority of the tender is satisfied with the documents in the envelope marked part I are in order, the other sealed cover marked Part II will be opened subsequently after the approval of competent authority of CMD.
  18. Earnest Money is liable to be forfeited if the successful tenderer selected for the work fails to sign the formal agreement as per format within 15 days from the date of issue of the Order Letter to them by the Company.
  19. The validity period of the tender shall be at least 120 days from the date of opening of the Technical bid. This period may be extended with mutual consent if the decision regarding issueof order letter is delayed for any reason.
  20. The work will be awarded to the overall lowest price bidder from among of the technically acceptable bidders.

**PARTICULARS****FABRICATION, SUPPLY & INSTALLATION OF WOODEN EXHIBIT CABINETS FOR GEO SCIENCE MUSEUM PH-2, GWALIOR.**

Last Date for submission of Offer	:	10-10-2023 (3.00 PM)
Place for submission of Offer	:	<b>Tender Box, 4<sup>th</sup> floor</b> of Creative Museum Designers, 33, Block GN, Sector V, Bidhannagar, Kolkata- 700 091.
Tender Opening Date (Technical Bid)	:	10-10-2023 (4.00PM) (for Part-I)
Tender Opening Date (Financial Bid)	:	The date for opening Part-II containing Financial Bid will be intimated to the qualified tenderers separately.
Validity of the Offer	:	120 days from the date of opening of the Technical bid.
Time Schedule for completion of work	:	45 days + 10 days of mobilization from the date of award of the work.
Security Deposit	:	10% of the total value of the work. It is to be retained during the defect liability period.
Site Address	:	GEO-SCIENCE MUSEUM GWALIOR OLD VICTORIA MARKET, JIWAJI CHOWK, GWALIOR, MADHYA PRADESH 474001.
Defect Liability Period	:	12 months from the approved date of completion.
Liquidated damage for non-completion of work in time	:	01% per week of the contract value, subject to a maximum 10% of the contract value of the work.
EMD	:	₹ 60,000.00/- ( <b>Rupees Sixty Thousand Only</b> ) by way of Demand Draft/Pay Order or Banker's Cheque/NEFT of any Nationalised/ Scheduled Commercial Bank in favour of Creative Museum Designers payable at Kolkata.



## **Creative Museum Designers**

*(A Section 8 Company Guaranteed by National Council of Science Museums)*

*Govt. of India*

*33 Block- GN, Sector-V, Bidhannagar,*

*Kolkata-700 091*

**Tender No. CMD- 007.12.52.1(WORKS)/23-24/18**

### **Instructions for Filling up the Tender**

- 1 The instructions, specifications, drawings and General Terms and Conditions given herein will be strictly binding on the tenderers and deviation, if any, shall make the tender liable to be considered invalid. Tenders incorporating additional conditions by the tenderers are liable to be rejected.
- 2 Tender must be submitted in two separate sealed covers marked PART – I (Technical Bid) and PART – II (Financial Bid) superscribing “**FABRICATION, SUPPLY & INSTALLATION OF WOODEN EXHIBIT CABINETS FOR GEO SCIENCE MUSEUM PH-2, GWALIOR.**” Bids of only the qualified tenderers/bidders shall be opened.
- 3 The tenderers shall fill up the enclosed “Offer Form” and submit the same along with the “General Terms and Conditions”, “Technical Specifications for **FABRICATION, SUPPLY & INSTALLATION OF WOODEN EXHIBIT CABINETS FOR GEO SCIENCE MUSEUM PH-2, GWALIOR.**”, and “Declarations” in a sealed envelope duly signed and stamped on all pages as a token of their acceptance.
- 4 Incomplete offers i.e. offers received without prescribed “Offer Form” “General Terms and Conditions”, “Technical Specifications for **FABRICATION, SUPPLY & INSTALLATION OF WOODEN EXHIBIT CABINETS FOR GEO SCIENCE MUSEUM PH-2, GWALIOR.**”, and “Declarations” duly signed with official seal on all pages will be rejected straightway without any reference to the tenderers.
- 5 Telegraphic and conditional offers shall not be accepted.
- 6 **Overwriting** in the “Price Offer Form” is not permitted and shall be rejected straightway without any further reference.
- 7 Offers should be submitted in sealed cover along with the requisite **Earnest Money Deposit.**
- 8 **Tenderer should be in possession of: -**  
Trade License, PAN Card [in the name of firm/agency or proprietor], P-Tax registration, Registration under the Shops & Establishment Act, GST Registration. The agency or any of its partners /directors etc. should not have been blacklisted/ debarred by any of the

government agencies or departments or should not have been found guilty of commission of acts of moral turpitude or convicted for any economic offence or for violation of any labour laws etc. by any court or any authority appointed to enforce any labour laws. Further no past contract of such agency should have been terminated in the past 3 years on account of violation of laws or deficiency of services or breach of contract.

9 Intending tenderers/bidders must read the terms and conditions of tender carefully. They should submit their bid only if they consider themselves eligible as per the laid down criteria and if they are in possession of all the documents/registrations required.

10 The contents of PART – I and PART – II must be as per clause 16 above.

### **11 Opening of Bids**

Part - I will be opened on the date, time and at the venue already indicated. After evaluation of the Technical Bid, CMD shall open the Part-II/Financial Bid of only those tenderers who have been declared technically qualified by CMD. The date for opening Part-II containing Financial Bid will be intimated to the qualified tenderers separately.

### **12 PRE-BID MEETING AND CLARIFICATIONS**

#### **i. Pre-bid Meeting**

- a) CMD shall hold a pre-bid Meeting with the bidders on **25<sup>nd</sup> September 2023 at 3.00 PM** at the conference room of CMD.
- b) The bidders will have to ensure that their queries, if any, for the pre-bid meeting reach CMD by email at **cmd.ncsm.curator@gmail.com** and **cmd.ncsm.edl@gmail.com** by **12.00 PM on 25<sup>nd</sup> September 2023**.
- c) The queries should necessarily be submitted in MS Word file in the following format:
- d) Any requests for clarifications submitted post the indicated date and time shall not be entertained by CMD.

Sl. No.	Reference(s) (Clause & Page No.)	Content requiring Clarification(s)	Points of Clarification
01.			

#### **ii. Responses to Pre-Bid Queries and Issue of Corrigendum/Addendum (if any)**

- a) CMD will endeavour to provide timely responses to all queries. However, CMD neither represents nor warrants as to the completeness or accuracy of any response made in good faith, nor does CMD undertake to answer all the queries that have been submitted by the bidders. At any time prior to the last date for receipt of bids,

CMD may, for any reason, whether at its own initiative or in response to a clarification requested by a prospective bidder, modify the tender document by a corrigendum or addendum;

- b) Any such corrigendum/addendum shall be deemed to be incorporated into this tender document and shall form part of the tender document;
- c) In order to provide prospective bidders reasonable time for taking the corrigendum/addendum into account, CMD may, at its discretion, extend the last date for the receipt of the bids.

### **13 Language**

The bid as well as all correspondence and documents relating to the bid to be exchanged by the bidder and CMD shall only be in English.

**ANNEXURE-I**

**PART OF: TECHNICAL BID**

**DETAILS OF BIDDER PARTICIPATING IN THE TENDER**

Sl.	Description	To Be Filled By The Agency
1.	Name of the Agency	
2.	Year of Establishment	
3.	Registered office with full address	
4.	Full Postal Address of communication	
5.	Telephone Number(s) of office	
6.	Contact person Name with Mobile No.	
7.	Fax number	
8.	E-Mail ID	
9.	Website if any	
10.	Nature of Entity - Limited Company, Partnership etc. (attach copy of partnership Deed/ Certification of incorporation as applicable)  Date of Incorporation	
11.	Name (s) of Director / Proprietor / Partners with address and telephone nos. if any	
12.	Qualification Criteria: <b>A. Techno Commercial Criteria:</b> The bidders should have experience in executing similar work i.e. fabrication, supply & installation of wooden exhibit cabinets or wooden exhibit-related work in Govt./Semi Govt./Public Sector/ Corporate offices, of having minimum contract value as indicated below in the last 3(Three) years reckoned from the due date for submission of the bid.  I. One contract having minimum value of 80% of the total estimated project value of the tender i.e 20.80 Lakhs.  II. Two contracts each having minimum value of 50% of the total estimated project value of the tender i.e. 13 Lakhs.  III. Three contracts each having minimum value of 40% of the total estimated project value of the tender i.e 10.40 Lakhs.	
13.	PAN of Bidder	
14.	GSTIN of Bidder	

**Details of other organisations where such contracts were undertaken during the last three years (enclose supporting documents and completion certificate).**

Sl.	Name & Address of the organization, contact No	Description of Work	Value of Work	Whether Govt./semi Govt./Autonomous bodies/PSUs/Industries etc.(Pl. specify)
1.				
2.				
3				
4				
5				
6				
7				
8				
9				
10				

I/We hereby solemnly declare that all the information/statements are true to the best of my/ our knowledge. I/we also declare that my/our firm is not involved in any Litigation or Arbitration with any company for the last 5 years. I/We further declare that the decision of Creative Museum Designers regarding the finalization of Empanelment of contractors shall be final and binding on me/us.

(Signature with date & seal)

N.B-1.: duly signed and stamped photocopies of all documents must be submitted along with the Technical Bid.

**CHECK-LIST (TECHNICAL BID)**

Sl.	Description of requirement	Yes/No
1.	Copy of Labour Licence	Yes/No
2.	Copies of <b>Balance Sheet and P&amp;L A/c</b> for the last 3 financial years duly certified by CA	Yes/No
3.	Copy of GST Registration	Yes/No
4.	Copy of <b>PAN</b> from Income Tax Department	Yes/No
5.	<b>Annexure-I</b> with supporting documents	Yes/No
6.	Proforma containing details of other organisations where such Work Were /are undertaken (attach supportive documents)	Yes/No
7.	₹60,000/- as EMD	Yes/No
8.	Price bid proforma completed & sealed in a separate envelope	Yes/No
9.	List of Arbitration cases (if applicable) <b>Do not leave it blank. If there are no cases, write “Not Applicable”.</b>	Yes/No/Not applicable
10.	<b>Acceptance of Terms and Conditions</b> attached. Each page of terms and conditions to be duly signed and stamped as token of acceptance and submitted as part of the tender document.	Yes/No
11.	<b>Copy of last 03 ITR</b>	Yes/No
12.	<b>Undertaking by the bidder</b> to the effect that there is no police case pending against the proprietor/firm/parties relating to previous service contracts.	Yes/No
13.	Office address in Kolkata, West Bengal.	Yes/No
14.	All Declarations	Yes/No

**NOTE: Submission of all the documents mentioned above along with the declarations, is mandatory. Non-submission of any of the information above may render the bid to be rejected.**

## **Creative Museum Designers**

*(A Section 8 Company Guaranteed by National Council of Science Museums)*

*Govt. of India*

*33 Block- GN, Sector-V, Bidhannagar,*

*Kolkata-700 091*

### **Tender No. CMD- 007.12.52.1(WORKS)/23-24/18**

#### **GENERAL TERMS AND CONDITIONS (GTC) REGARDING SUBMISSION OF TENDER FOR FABRICATION, SUPPLY & INSTALLATION OF WOODEN EXHIBIT CABINETS FOR GEO SCIENCE MUSEUM PH-2, GWALIOR.**

1. The tenderer shall be required to take up the job for “**FABRICATION, SUPPLY & INSTALLATION OF WOODEN EXHIBIT CABINETS FOR GEO SCIENCE MUSEUM PH-2, GWALIOR.**” as per the enclosed specification.
2. The successful tenderer shall submit the following documents within 7 (seven) days from the date of placement of the work order.
  - a. **Duplicate copy of the work order duly signed and stamped by the tenderer as a token of acceptance of the order.**
  - b. **Security Deposit as detailed in Clause no. 8 of General Terms and Conditions.**
3. **Price:**
  - i) The rates quoted/indicated shall include cost of all materials, labour for fabrication, machining, assembling, testing, painting, polishing, finishing, supply, erection, installation, labour supervision and all working accessories, tools and tackles, reliable standard testing equipment etc. and including all handling charges to supply and deliver and install wooden structures strictly as per the drawings provided by Creative Museum Designers, Kolkata.
  - ii) The rates quoted in the Offer Form for cost of fabrication should be tax exclusive. Taxes, duties etc. as applicable to be mentioned separately. Price and rate quoted shall be firm and fixed for the entire period of execution of the work and no escalation of rate on any ground whatsoever shall be allowed. All the statutory deductions such as GOVT. CESS/ TDS as per Income Tax Act at prevailing rates shall be deducted from the bill(s) of the contractor.
  - iii) The work will be awarded to overall lowest technically acceptable bidder for the work, as per prices quoted in the Offer Form.

#### **4. Time of Completion:**

Time is the essence of this tender. The entire work viz. fabrication, supply, erection, and installation of wooden structures as per enclosed specification and drawings after obtaining approval at different stages of work shall be completed within 45 days + 10 days of mobilization period from the date of placement of order.

- a. In the event of delay in execution of work wholly attributable to delay in supply of drawings/modified drawings by the Company (CMD) despite a request from the successful tenderer made well in advance, he shall apply in writing to the Project In-charge/CMD within 07 days from the date of the hindrance on account of which he desires such extensions and the Project In-charge, with the consent of the consideration of the Company may (if the reasons for extension is found acceptable) allow such extension of time as deemed reasonable by CMD.
- b. In case of the total value of the work exceeds the total contract value of the tender owing to deviation in quantities or extra items, the successful tenderer will be entitled to ask for an extension of time in proportion to the increased value of work.
- c. No extension of time shall be given to the successful tenderer for non-supply or delay in supply of requisite materials. The successful tenderer hereby agrees that the extension of time requested for by him and granted by the Company shall be treated as an extension of time allowed to them without any claim for compensation or damages for any reasons whatsoever including those for which the extension is granted.

#### **5. Penalty Clause (Liquidated damage):**

The successful tenderer shall strictly observe the time allowed for carrying out the works as detailed in clause no.4. The work shall, throughout the stipulated period of the contract, be proceeded with all diligence (time being deemed to be the essence of the contract) and the tenderer shall pay to the Creative Museum Designers, Kolkata an amount equal to 1% of the amount of the Contract value for every week that the work may remain incomplete as per delivery schedule as stipulated in clause no.4, subject to a maximum compensation of 10% of the contract value after which period appropriate action will be taken by Creative Museum Designers as will be deemed fit. Over and above, in case of non-compliance with the strict time schedule for the project by the successful bidder, CMD will have the option of freezing any further payment.

6. Every effort shall be made to complete the work/job by the successful tenderer within the specified time schedule. In case the firm fails to comply with Clause No. 4 i.e. within the specified time schedule as per the finalized and accepted terms and conditions, Creative Museum Designers shall have the right to either impose penalty Clause or cancel the order or both at its discretion. Creative Museum Designers may get the unfinished work done at the risk and cost of the successful tenderer. The decision of Creative Museum Designers in this regard shall be final and binding on the successful tenderer.



## **7. Inspection:**

Inspection may be carried out at any time during the process of fabrication, if desired by the officials of Creative Museum Designers, Kolkata. Any defect pointed out by the competent representative of the Creative Museum Designers during such inspections shall be promptly rectified to ensure the desired quality of work. It would be mandatory on the part of the successful tenderer to arrange inspection and obtain approval at every stage of work failing which action will be taken as deemed fit by the CMD. The decision of CMD in this regard shall be final and binding on the successful tenderer.

## **8. Security Deposit:**

The successful tenderer shall submit a Security deposit amounting to 10% of the value of the order (i.e. the gross amount). If the Security Deposit is not deposited before the commencement of the work, deduction @ 10% shall be made from each Bill and the said amount shall be retained by CMD as Security Deposit (which includes the EMD submitted by the tenderer shall be converted into initial security deposit and balance amount shall be deducted from the bill). CMD may forfeit the SD if the successful tenderer fails to rectify the defects pointed out by CMD during DLP. The Security Deposit of the successful tenderer shall be released after expiry of the defect liability period (defect liability period shall be 12 (twelve) months from the date of final completion of the work/job). No interest shall be paid on the security deposit retained with Creative Museum Designers, Kolkata.

## **9. TERMS OF PAYMENT:**

No advance payment shall be made by Creative Museum Designers, Kolkata under any circumstances. One interim payment and one Final Payment shall be released as below:

- i) 50% of the payment will be released after 60% of the work is over (value of the awarded work).
- ii) Rest will be payable after successful completion of the work.

Payment will be released within 30 (Thirty) days from the date of receipt of Invoice/Bill duly supported by receipted challan and satisfactory inspection/work completion certificate from CMD authority for the entire job.

## **10. Defect Liability Period:**

The defect liability period shall be 12 (twelve) months from the date of completion of the work. The successful tenderer will be responsible for all defects in the material supplied or non-supply of standard material as per tender, defective workmanship, use of defective materials, de-colouring of material, material breakage etc. for a period of 12 (twelve) months from the date of completion of the job.

11. Specifications of the items under tender are as given in the enclosed tender documents along with drawings. However, if any ambiguity in the specification is detected, it shall be promptly brought to the notice of Creative Museum Designers, Kolkata for

clarifications. No deviation from the approved specifications shall be made by the successful tenderer without the written approval of Creative Museum Designers, Kolkata.

12. The authorities of Creative Museum Designers, Kolkata reserve the right to amend, alter or modify the terms & conditions or quantities mentioned above if necessary.
13. The authorities of Creative Museum Designers, Kolkata, who do not bind themselves to accept the lowest tender, reserve the right to reject or accept any or all tenders wholly or partially without assigning any reason whatsoever.
14. The CMD shall not be liable for any kind of injury resulting in temporary or permanent disability or loss of life of any employee or worker who is deployed by the successful tenderer within/outside the working space at GEO-SCIENCE MUSEUM GWALIOR OLD VICTORIA MARKET, JIWAJI CHOWK, GWALIOR, MADHYA PRADESH-474001, site at the time of execution of the said work.
15. The successful tenderer shall pay not less than minimum wages as prevalent in the concerned municipal area and shall abide by all and every kind of legislation that are incidental to and concerned with engagement of persons for the time being for carrying out and execution of the work. CMD shall have no liability of any kind with regard to the workers employed/ deployed by the successful tenderer.
16. The successful tenderer shall ensure that all wages and allied benefits as per statutory norms are paid to their workers for the purpose of this contract. The Agency shall remain liable to the authorities concerned for compliance with respective existing rules and regulations of the Govt. for the purpose of this contract and shall remain liable for any contravention thereof. They shall keep CMD indemnified against any liabilities arising out of non-compliance with any of the acts, rules, orders of the Govt./ Company on their part.
17. The Creative Museum Designers, Kolkata or its representatives shall, at all reasonable time, have free access to the works and/or to the workshops/factories or other places where materials are being prepared or fabricated for the contract and also to any places where material is lying or from which they are being obtained and the successful tenderer shall provide assistance to them for inspection, examination and testing of the materials and workmanship. Except the representatives of Public Authorities and those mentioned above, no person shall be allowed in the working place at any time without the prior written permission of CMD, Kolkata.
18. The successful tenderer shall obtain necessary trade and other licenses as may be required to carry out the tendered job and shall also be responsible for compliance with all rules and regulations which may be in force from time to time by the appropriate authority at his/their own cost. They will also provide all necessary **Workmen's Compensation Insurance Policy** and **Labour Licence** for the workers engaged by the agency at the site.

19. CMD reserves the right to allow other team of personnel/contractor to work at the work site.
20. The successful tenderer shall ensure that, during the course of execution of the work under the present contract, no damage is caused to the existing property or structures. In case of any damage arising out of the contractor's work/ negligence, it has to be repaired by the agency or the same will be done by CMD at the cost of the contractor. In case of any theft, loss of assets and/or disturbance adversely affecting day to day job etc., to the working place, the entire responsibility for recovery and legal actions starting with the lodging of F.I.R. with local police in consultation with the authorities of the CMD, up to the final recovery stage etc. will lie with the agency.
21. The successful tenderer should mandatorily maintain a **Hindrance Register** at the working site to record all hindrances encountered during execution of the work. The reason and item of work affected due to any hindrance shall be clearly recorded in the Hindrance Register and the Project-in-Charge/employee of CMD as well as the Contractor/representative of Contractor will sign on the register for the recorded hindrance. In case of several hindrances encountering simultaneously over a period of time affecting the same item or different items of the work, the period of hindrance will be worked out by CMD. The format of Hindrance Register is provided hereunder:

**FORMAT OF HINDRANCE REGISTER**

**Tender No. CMD- 007.12.52.1(WORKS)/23-24/18**

Description of work:	Work Order No., Date:
Name of the Contractor:	Scheduled Completion Time:

Sl.	Nature of Hindrance	Items of work not executed due to hindrance	Date of start of hindrance	Date of end of hindrance	Period of Hindrance	Net hindrance day	Remarks
Signature of Contractor					Signature of Project-in-Charge		

**22. ARBITRATION**

In the case of any disputes or differences arising out of or in connection with, or concerning this Agreement, it shall be settled by arbitration. The arbitration shall be conducted by an expert as Arbitrator in the field acceptable to both the parties. In case of disagreement, it shall be through three experts in the field, one to be appointed by each party and the third presiding expert to be jointly appointed by the two experts referred to. The arbitration shall be as per the provision of the Arbitration and

Conciliation (Amendment) Act, 2015 and the decision of the panel so appointed shall be final and binding on both the parties to this Agreement. The place of arbitration shall be normally Kolkata or any other suitable place mutually agreed.

The provisions of the Arbitration and Conciliation Act 2015 or any statutory modification or re-enactment there of and of the rules made there under for the time being in force shall apply to arbitration proceedings under this clause.

### **23. FORCE MAJEURE EVENT (FME)**

If there is a delay in performance or other failures by the contractor to perform its obligation under its contract due to the event of a Force Majeure as mentioned hereunder, the contractor shall not be held responsible for such delays/failures. If a force majeure situation arises, the contractor shall promptly apply in writing to the Project In-charge/CMD within 07 days or as soon as it occurs and it cannot be claimed ex-post facto:

- a. by reason of any exceptionally inclement weather like Cyclone, severe flood etc., normal monsoon shall not be considered a valid reason for the extension of time,
  - b. by reason of proceedings taken or threatened by, or legal disputes with adjoining or neighbouring owners,
  - c. by reason of any epidemics, quarantine restrictions etc. declared by the Government,
  - d. due to delay in the work of other agencies or tradesman engaged or nominated by the consideration of the Company: if such delay is directly responsible for delay in execution of this work,
  - e. by reason of any general strike or lockout affecting work, strike or any kind of labour trouble in successful tenderer's organisation shall not be a valid reason for the extension.
  - f. There may be a Force Majeure situation affecting the Tenderee (CMD) only, under which the Tenderee (CMD) shall have equal rights to claim relief under such Force Majeure situations.
24. The successful tenderer should furnish documentary proof in support of **GST number and PAN number** of their establishments. Payment will not be released till such certificate is furnished.
25. The successful tenderer must submit the following Registrations/Certificates to the office of CMD, Kolkata prior to execution of the agreement or within 07 days of issuance of LOI whichever is earlier. Failing which the order will be summarily cancelled:
- a. **Labour Licence** at GWALIOR, MADHYA PRADESH.
  - b. **Workman Compensation Insurance Policy** for labours engaged at site.
26. The Agency shall make Police verification of the particulars of their personnel deployed and issue proper identity cards to those personnel/labour who are deployed by them at any point of time for the purpose of this contract in order to facilitate verification of their identity by the CMD. They shall always wear the photo identity card while inside the premises of the working place / site / Centre. The details of the labours deployed at

the site must be submitted to CMD authority along with the proof of address and one copy of passport size photograph.

27. The Agency on completion of the contract or on termination of the contract shall peacefully vacate the premises of the working place / locations / site / centre and remove all their persons and materials from the campus after handing over the charge to the new agency/Party.
28. The Agency shall be responsible for observance and compliance of different industrial laws as in force and they shall ensure that no demonstration/agitation of any kind takes place inside or near the premises of the working place / locations / site /centre by personnel engaged by the Agency.
29. The CMD shall pay to the Agency nothing more than the amount as may be due under the contract terms.
30. Contractor shall keep a qualified and experienced Engineer for supervision of work to ensure the best quality of work. The agency should ensure all the safety equipment like helmets, safety glasses, gloves, shoes, etc. are used by the workers during the execution of the work.
31. The tenderer shall be responsible for arranging and maintaining at his/her own cost all materials, tools, tackles, machines required for fabrication, material handling equipment, ladders, benches, water, electricity access, and other facilities for workers and all other services required for executing the work.
- 32. Whenever there is a duplication of clause either in the terms and conditions or in the tender document, the clause which is beneficial to CMD will be considered applicable at the time of any dispute/following any statutory rules.**

## **Creative Museum Designers**

*(A Section 8 Company Guaranteed by National Council of Science Museums)*

*Govt. of India*

*33 Block- GN, Sector-V, Bidhannagar,*

*Kolkata-700 091*

### **Tender No. CMD- 007.12.52.1(WORKS)/23-24/18**

#### **TECHNICAL SPECIFICATIONS REGARDING “FABRICATION, SUPPLY & INSTALLATION OF WOODEN EXHIBIT CABINETS FOR GEO SCIENCE MUSEUM PH-2, GWALIOR.”**

##### **(A) Material specification for the Work:**

1. Use only new and latest stock of BWP plywood of Century make (Bond 710) / Greenply make (Green Ecotec Platinum 710) with minimum 15 years' warranty along with the test certificate from Govt. recognised body/institute. These are to be got approved by competent authority of CMD before using in fabrication. Ply marked with Greenply/Century of specified grade only will be accepted. All curved surfaces should be made with 6mm flexible plywood of Century/ Greenply make or equivalent.
2. Unless specified, for all the frameworks for cabinets, fully seasoned good quality knot and crack free Teak Wood to be used. Use 25mm x 50mm Teak wood for vertical frame members and 25mm x 50mm for horizontal frame members and 50mm x 50mm for Base. Use the wooden sections as per specification given in the drawing.
3. If demanded test certificate for Teak wood used has to be provided from any Govt. Test house within a week.
4. Agency must use seasoned, knot free, straight wooden battens for the work. If after installation the wooden structure develops a bend within the defect liability period, then the agency has to take up necessary modification work without causing any damage to the existing display system. Otherwise, the work shall be taken up by the company at agency's risk and cost and the amount will be deducted from the security deposit. The penalty charges will be decided by CMD officials.
5. All laminates will be 1mm thick or as per drawing of Century / Greenlam make unless otherwise specified. Agency should take approval from CMD regarding the shades before using for fabrication work.
6. Wherever the finish is to be done with veneer, it will be of exquisite and superior quality veneer which after polish will give the actual finish of texture. Before pasting of such veneer it has to be got approved by the authority of CMD. All veneer will be of 4mm thick Century / Greenlam make.
7. Stainless steel structures if any must be of Grade 316/304/202 as approved by CMD Authority , which are to be buffed and polished to produce matt/mirror finish as desired by CMD.

8. MS structures if any should be with primer and colour coated as approved by CMD.
9. All the visible surfaces of partition area should have laminated / painted/ veneered/ polished finish. Refer to specifications for laminated finish and paint finish as per details given in Section (B) and (C).
10. All the non-laminated portion should be painted with one coat of 1<sup>st</sup> quality wood primer after that it should be applied with 2 or more coats of paint to get even finish with approved colour. The paint shall be synthetic enamel paint of Berger/Asian/ ICI make of approved colour.
11. Use Fevicol (SH) adhesive for frame joining; ply fixing on frames.
12. All the exhibit structures to be firmly grouted to the floor / walls etc. as per direction at site.
13. All wooden/plywood/laminated surfaces mandatorily required to be treated with anti-termite agent. Agency should provide warranty for five years for the treatment.
14. All wooden beadings used for fixing of Glass / acrylic / polycarbonate sheets shall be Teak Beading and polished finish / metallic paint finish.
15. All clear glass used in the cabinets should be only toughened float glass of Modi Guard or Saint Gobain make and should be clear, transparent, wrinkle and scratch free as per specified thickness.
16. All glass mirror used in the cabinets should be of Modi Guard or Saint Gobain or equivalent make as approved by CMD, wrinkle and scratch free with specified thickness.
17. Transparent polycarbonate, acrylic sheets and acrylic mirror free from any scratches or stains, shall only be used. Samples must be got approved before using in fabrication jobs.
18. All Dimensions given in the drawings are in millimetre unless otherwise specified.
19. Dimensions given in the drawings are indicative. The actual dimensions for fabrication may vary depending on site condition.
20. CMD may inspect/test any materials to be used/supplied by the agency for its genuineness from the registered laboratory.
21. CMD may ask for inspection/test report of any materials to be used/supplied by the agency for its genuineness from the registered laboratory whenever required.

22. Stage inspection and supervision shall be carried out on regular basis during the entire period of fabrication by the competent authority of this museum. Modifications pointed out during inspection and required for better design of the structures, should be carried out before finally completing the work and leaving the site.
23. Laminate sheets, pasted on any two meeting surfaces, shall be mitred.
24. The tenderer shall be responsible for arranging and maintaining at his/her own cost all materials, tools, tackles, machines required for fabrication, material handling equipment, ladders, benches, water, electricity access, and other facilities for workers and all other services required for executing the work.

**(B) Specification for pasting assorted plain colour / decorative laminates/ veneer on wall panels:**

1. The selected tenderer shall use latest stock of Century / Greenlam make 1mm thick assorted plain colour decorative laminates and customised decorative laminates conforming to IS: 2046:1995 as per the colour scheme required for individual cabinets.
2. The selected tenderer shall undertake pasting of laminates as per approved design that may be plain or designed using multiple colour shades.
3. All decorative laminates/ veneer shall be pasted with Fevicol SH only.
4. Edges of laminates if any shall be beveled before pasting to avoid visibility of the edges etc. Sharp corners should be properly ground.
5. Adequate measures shall be taken to ensure proper pasting of laminates to avoid any air bubbles, undulations etc.
6. In case workmanship of laminate pasting is found defective and unsatisfactory due to formation of air bubbles, undulation etc. during inspection, the successful tenderer shall arrange to replace the laminates at his/her own cost as per the approved shade and make.

**(C) Material specifications for MRF/AkzoNobel make polyurethane paint with PU clear glossy/ matt finish on wooden & metallic surfaces, wherever required.**

1. All paints, primers, filler materials and thinner only shall be supplied by the selected tenderer as per actual requirement.
2. The wooden / plywood surfaces shall be thoroughly cleaned with emery paper 60/80/120 to make the surface smooth before application of the penetration primer and subsequent coats of knifing filler, soft cutting filler, glossy / metallic polyurethane paint and clear glossy/matt polyurethane paint. Manufacturer's specifications, applications, and application procedure shall be strictly followed to ensure the desired quality of finish.



3. The successful tenderer shall arrange to bring their own spray gun, compressor for spray painting and tools and tackles required for the work.
4. Rest of the specifications are given in the enclosed drawings.

**(D) No deviation on any of the following points will be accepted in any circumstances. Brands as specified must be followed strictly.**

1. All major dimensions are provided in hard copy of the drawings. The detail dimensions of any individual members or structures if required may be obtained from the Auto-cad drawings. In case of any clarification required, the agency may contact to this office before submission of the offer.
2. All Glasses are toughened clear glass without any dent and scratches.
3. Exact colour scheme of laminates/veneer and fixing pattern will be made available at the time of fabrication. Party has to arrange the required shade from either of the make as specified in the specification of laminates in clause no. (01) of technical specification, Section B.
4. Wherever needed Service door of minimum size should be provided with frame work and mortise lock. Locks are to be provided and fixed by the party.
5. The non-laminated pasted portion of structure including portion visible from service corridor should be paint finished using approved colour and shade of 1st grade Berger/Asian paints make first quality synthetic enamel in two or more coats on wood primer of similar make.
6. All the MS/Stainless Steel works are to be executed as per drawing. The entire SS surface is to be buffed and polish finished and MS structures should be with primer and colour coated as approved by CMD.

**(E) Specification for Vertical straight and Curved paneling, Horizontal Base/ Floor and Roof of exhibit cabinets and gallery:**

1. Straight paneling work should be made with 9mm / 12mm ply (whichever has been mentioned in the drawing) over the frame structure of 25mm x 50mm Teak section at the periphery and all the vertical and horizontal members will be of 25mm x 50mm Teak section with a grid size of 400mm x 400mm.
2. All curved surfaces are to be made by 25mm x 50mm Teak wood section with 450mm gapping (vertical) and two nos. of 12mm (t) x 50mm (w) curved cutting of 12mm ply glued with Fevicol SH making a thickness of 25mm for horizontal members with a gap of 300mm thus making a grid of 400mm x 300mm.
3. All vertical surfaces will be of 9mm ply, unless otherwise specified. All horizontal surfaces up to the height of 3 ft. will be of 12mm ply and horizontal surfaces beyond the height of 3 ft. will be of 6/9mm ply.

**Creative Museum Designers**

*(A Section 8 Company Guaranteed by National Council of Science Museums)*

*Govt. of India*

*33 Block- GN, Sector-V, Bidhannagar,*

*Kolkata-700 091*

**Tender No. CMD- 007.12.52.1(WORKS)/23-24/18**

**DECLARATION - 1**

We, do hereby accept the General Terms and Conditions as provided by the CREATIVE MUSEUM DESIGNERS, KOLKATA along with tender documents for “**FABRICATION, SUPPLY & INSTALLATION OF WOODEN EXHIBIT CABINETS FOR GEO SCIENCE MUSEUM PH-2, GWALIOR.**” and also undertake to execute the job strictly as per the drawing and specifications as provided along with the tender documents in the event of placement of any work order on us.

Signature of the tenderer / Constituted Attorney.

(With date and Official Seal)

**Creative Museum Designers**

*(A Section 8 Company Guaranteed by National Council of Science Museums)  
Govt. of India  
33 Block- GN, Sector-V, Bidhannagar,  
Kolkata-700 091*

**Tender No. CMD - 007.12.52.1(WORKS)/23-24/18**

**DECLARATION - 2**

**OF NON-RELATIONSHIP**

It is certified that I/We, the undersigned, do not have relationship with any of the employees working at Creative Museum Designers.

The above statement is true and is submitted against the Tender No. CMD-007.12.52.1(Works)/23-24/18 of Creative Museum Designers.

Signature of the tenderer / Constituted Attorney.

(With date and Official Seal)

**FORMAT OF ARTICLES OF AGREEMENT**

ARTICLES OF AGREEMENT made at **Kolkata** this .....between the **Creative Museum Designers** at NCSM Campus, CRTL Building- II, 33, Block GN, Sector - V, Bidhannagar, Kolkata- 700091 (Registered under Section 25 of the erstwhile Companies Act, 1956) and a wholly owned Company of National Council of Science Museums (a Society registered under the Societies Registration Act of West Bengal 1961) hereinafter referred to as the CMD which expression shall include its successors and assigns on the one part and **M/s. ABCD Private Limited** having its registered office at **XYZ**, hereinafter referred to as the Successful Tenderer which expression shall include his/their respective heirs, executors, administrators and assigns on the other part.

WHEREAS the CMD is desirous of getting the work of "**FABRICATION, SUPPLY & INSTALLATION OF WOODEN EXHIBIT CABINETS FOR GEO SCIENCE MUSEUM PH-2, GWALIOR.**" therein done and has caused Notice Inviting Tender (Including appendix), schedule of quantities and specifications describing the work and conditions of contract prepared by **Creative Museum Designers, 33, Block – GN Sector –V, Bidhannagar, Kolkata – 700091.**

AND WHEREAS the said NIT (including appendix), specifications and the conditions of contract have been signed by or on behalf of the parties hereto.

AND WHEREAS the Successful Tenderer has deposited in Demand Draft a sum of Rupees Sixty Thousand only with the CMD as EMD for the due performance of this Agreement as provided in the said conditions of contract.

**NOW IT IS HEREBY AGREED AND DECLARED BY AND BETWEEN THE PARTIES HERETO AS FOLLOWS:**

1. In consideration of the payment to be made by the CMD to the successful tenderer as hereinafter mentioned, the successful tenderer hereby covenants with the CMD to perform execute and complete the work in conformity in all respects with the provision of the contract (**STRICTLY WITHIN** 45 days + 10 days of mobilization period from the date of the issue of Letter of Intent and as per the Technical Specification in Tender Document and detailed drawings).
2. CMD hereby covenants to pay the successful tenderer in consideration of the execution and completion of the work such sum as shall become payable hereunder at the time and in the manner prescribed in the said conditions and payment schedule.
3. Time is the essence of this Agreement and the Successful Tenderer shall pay or allow the CMD the sum equivalent to one per cent of the total cost of work awarded per week subject to a limit of 10% of the total cost of work as penalty for the period during which the said work shall remain incomplete beyond the time allowed in Clause-1 above or beyond the time duly extended in writing as per said conditions. The CMD may deduct such amount from any money due to the Successful Tenderer.
4. The Notice Inviting Tender (including Appendix if any), general terms and conditions of Contract, corrigendum (if any), addendum (if any), scope of work, drawings and technical specifications shall form the basis of this agreement and the decision of the CMD in reference to all matters or dispute as to material and workmanship shall be final and

binding on the Successful Tenderer.

5. The CMD reserves to itself the rights of altering the drawings and of adding to or omitting any item of work or of having portions of the same carried out departmentally or otherwise and such alterations or variations shall not vitiate this agreement.
6. This agreement comprises the work above and all subsidiary work connected therewith, even though such work may not be shown on the drawing or described in the said specifications.

### **ARBITRATION**

In the case of any disputes or differences arising out of or in connection with, or concerning this Agreement, it shall be settled by arbitration. The arbitration shall be conducted by an expert as Arbitrator in the field acceptable to both the parties. In case of disagreement, it shall be through three experts in the field, one to be appointed by each party and the third presiding expert to be jointly appointed by the two expert referred to. The arbitration shall be as per the provision of the Arbitration and Conciliation (amendment) Act, 2015 and the decision of the panel so appointed shall be final and binding on both the parties to this Agreement. The place of arbitration shall be normally Kolkata or any other suitable place mutually agreed.

The provisions of the Arbitration and Conciliation Act 2015 or any statutory modification or re-enactment thereof and of the rules made there under for the time being in force shall apply to arbitration proceedings under this clause.

### **FORCE MAJEURE EVENT (FME)**

If there is a delay in performance or other failures by the Successful Tenderer to perform its obligation under its contract due to the event of a Force Majeure as mentioned hereunder, the Successful Tenderer shall not be held responsible for such delays/failures. If a force majeure situation arises, the Successful Tenderer shall promptly apply in writing to the Project In-charge/CMD within 07 days or as soon as it occurs and it cannot be claimed ex-post facto:

- g. by reason of any exceptionally inclement weather like Cyclone, severe flood etc., normal monsoon shall not be considered a valid reason for the extension of time,
- h. by reason of proceedings taken or threatened by, or legal disputes with adjoining or neighbouring owners,
- i. by reason of any epidemics, quarantine restrictions etc. declared by the Government,
- j. due to delay in the work of other agencies or tradesman engaged or nominated by the consideration of the Company: if such delay is directly responsible for delay in execution of this work,
- k. by reason of any general strike or lockout affecting work, strike or any kind of labour trouble in successful tenderer's organisation shall not be a valid reason for the extension.
- l. There may be a Force Majeure situation affecting the Tenderee (CMD) only, under which the Tenderee (CMD) shall have equal rights to claim relief under such Force Majeure situations.

### **LANGUAGE**

All correspondence and documents relating to/relevant to this Agreement shall be in writing and only in English language.

In witness whereof the parties have set their respective hands the day and the year hereinabove written:

Signed by for and on behalf of the CMD.....  
(With official seal)

In presence of

(1).....

(2).....

Signed by the said Successful Tenderer.....  
(With official seal)

In presence of

(1).....

(2).....

## **Creative Museum Designers**

*(A Section 8 Company Guaranteed by National Council of Science Museums)*

*Govt. of India*

*33 Block- GN, Sector-V, Bidhannagar,*

*Kolkata-700 091*

### **PRICE OFFER FORM**

#### **Annexure-III**

**Tender No. CMD - 007.12.52.1(WORKS)/23-24/18**

### **FABRICATION, SUPPLY & INSTALLATION OF WOODEN EXHIBIT CABINETS FOR GEO SCIENCE MUSEUM PH-2, GWALIOR.**

I/We have read, understood and accepted all the General Terms and Conditions for **FABRICATION, SUPPLY & INSTALLATION OF WOODEN EXHIBIT CABINETS FOR GEO SCIENCE MUSEUM PH-2, GWALIOR.**, as per CMD's specifications as laid down in drawings by Creative Museum Designers, Kolkata.

I/We hereby offer my/our rates for the said tender: -

1. Name of the Tenderer :
  
2. Permanent address (in case of Firm/Company, address of the registered office including jurisdiction of the police station should be given) :
  
3. Telephone Nos.
  - a) Office :
  - b) Workshop/Factory :
  - c) Mobile :
  
4. Name of the Bankers and their address :

**05. PRICE OFFER****COST OF FABRICATION, SUPPLY & INSTALLATION OF WOODEN EXHIBIT CABINETS FOR GEO SCIENCE MUSEUM PH-2, GWALIOR.**

Sl. No.	Reference	No. of Drawings	Drawing Ref Number	Qty.	Amount (₹)
01.	Enclave-1	11	CMD-007.12.52.1/EN-1/1 (2) CMD-007.12.52.1/EN-1/2 (2) CMD-007.12.52.1/EN-1/3 (3) CMD-007.12.52.1/EN-1/4 (2) CMD-007.12.52.1/EN-1/5 (2)	1	
02.	Enclave-2	8	CMD-007.12.52.1/EN-2/1 (4) CMD-007.12.52.1/EN-2/2 (2) CMD-007.12.52.1/EN-2/3 (2)	1	
03.	Enclave-3	5	CMD-007.12.52.1/EN-3/1 (3) CMD-007.12.52.1/EN-3/2 (2)	1	
04.	Enclave-4	5	CMD-007.12.52.1/EN-4/1 (2) CMD-007.12.52.1/EN-4/2 (3)	1	
05.	Enclave-5	6	CMD-007.12.52.1/EN-5/1 (3) CMD-007.12.52.1/EN-5/2 (3)	1	
06.	Enclave-6	12	CMD-007.12.52.1/EN-6/1 (2) CMD-007.12.52.1/EN-6/2 (2) CMD-007.12.52.1/EN-6/3(2) CMD-007.12.52.1/EN-6/4 (2) CMD-007.12.52.1/EN-6/5 (2) CMD-007.12.52.1/EN-6/6 (2)	1	
07.	Enclave-7	9	CMD-007.12.52.1/EN-7/1 (2) CMD-007.12.52.1/EN-7/2 (3) CMD-007.12.52.1/EN-7/3(2) CMD-007.12.52.1/EN-7/4 (2)	1	
<b>TOTAL</b>					
<b>GST @ _____%</b>					
<b>GRAND TOTAL</b>					



**06. EXTRA WORK**

<b>Sl. No.</b>	<b>Scope of work</b>	<b>Unit</b>	<b>Qty.</b>	<b>Amount/unit in ₹</b>	<b>Total Amount in ₹</b>
<b>1</b>	<b>Vertical/ Horizontal Panel with 6/9/12 mm Ply on single side, straight, 1mm Laminate on wooden framing.</b>	<b>Square feet</b>	<b>150</b>		
<b>2</b>	<b>Vertical/Horizontal Panel with 3/6/9 mm Ply on single side, curved, 1mm Laminate on wooden framing.</b>	<b>Square feet</b>	<b>100</b>		
<b>3</b>	<b>Vertical/Horizontal Panel with 6/9/12 mm Ply on double side, straight, 1mm Laminate on wooden framing.</b>	<b>Square feet</b>	<b>150</b>		
<b>4</b>	<b>Vertical/Horizontal curved Panel with 3/6/9mm Ply on double side, curved, 1mm Laminate on wooden framing.</b>	<b>Square feet</b>	<b>100</b>		
<b>5</b>	<b>Wooden Work</b>	<b>Square feet</b>	<b>100</b>		
<b>6</b>	<b>MS Structure</b>	<b>kg</b>	<b>200</b>		
<b>7</b>	<b>SS Structure</b>	<b>kg</b>	<b>100</b>		
<b>8</b>	<b>Aluminium Structure</b>	<b>Sq. ft.</b>	<b>100</b>		
<b>9</b>	<b>Putty finish and Painting</b>	<b>Sq. ft.</b>	<b>100</b>		
<b>10</b>	<b>Clear Transparent glass of various thickness and Glass Mirror of Various thickness</b>	<b>Sq. ft.</b>	<b>200</b>		
<b>TOTAL</b>					
<b>GST @_____%</b>					
<b>GRAND TOTAL</b>					

**NOTE:**

**Parties should quote their rates for extra works in the table provided. For any extra work, as per site requirement will be executed on real time realisation and payment will be made as per the actual measurement. Rate of extra work will not be taken into account for evaluation of the lowest bidder for the work. The extra will have to be executed by the lowest bidder of the main work as per the rate quoted for extra work by that party.**

**However, the drawings may be changed according to the site measurement and exhibit requirement and will be updated accordingly.**

Before quoting please see the drawings enclosed and survey the site at **GWALIOR, MP** and may obtain clarification on any point from the authority before submission of rates.

The above rates quoted by us for **FABRICATION, SUPPLY & INSTALLATION OF WOODEN EXHIBIT CABINETS FOR GEO SCIENCE MUSEUM PH-2, GWALIOR** are strictly in accordance with the CREATIVE MUSEUM DESIGNERS, KOLKATA specifications and drawings and as per GTC.

**Validity of offer:** Validity of offer will remain up to 120 days from the date of opening of the Technical bid.

Date:

Signature of the Tenderer/Authorised Attorney

Official Seal

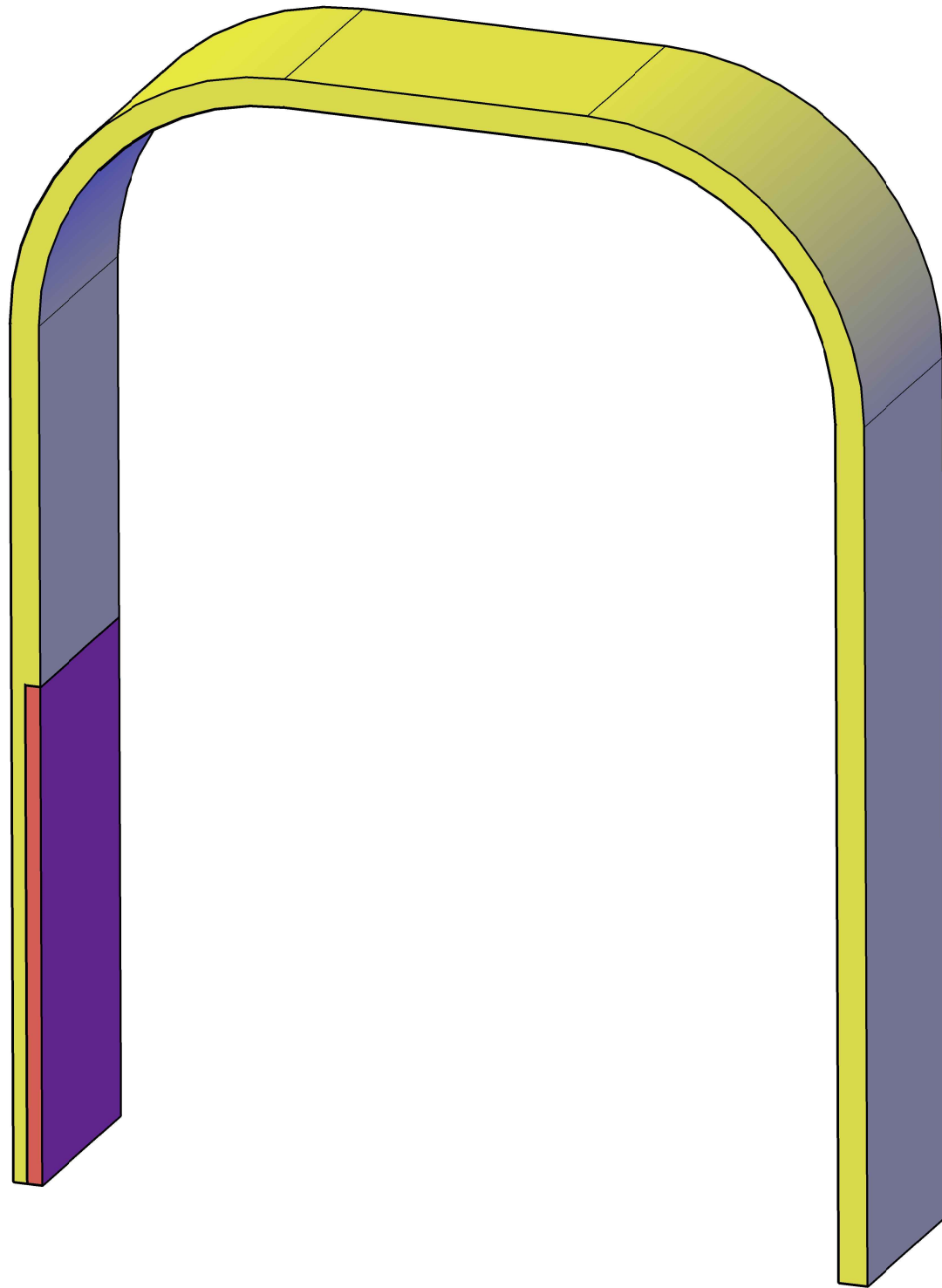

All Dimensions are in m.m.

<b>Creative Museum Designers</b>			
UNIT: Design Section		PROJ: GSI Gwalior Gallery - II	
DRG.NO. CMD-007.12.52.1/EN-1/1	DATE 01/08/2023	SCALE NTS	TOLERANCE
TITLE Gallery - II Entry Gate			NO OFF 01 OFF 02
Drawn By Mr. Pratik Saha	Checked By Mr. Susanta Shaw	Approved By Mr. K. S. Murali	

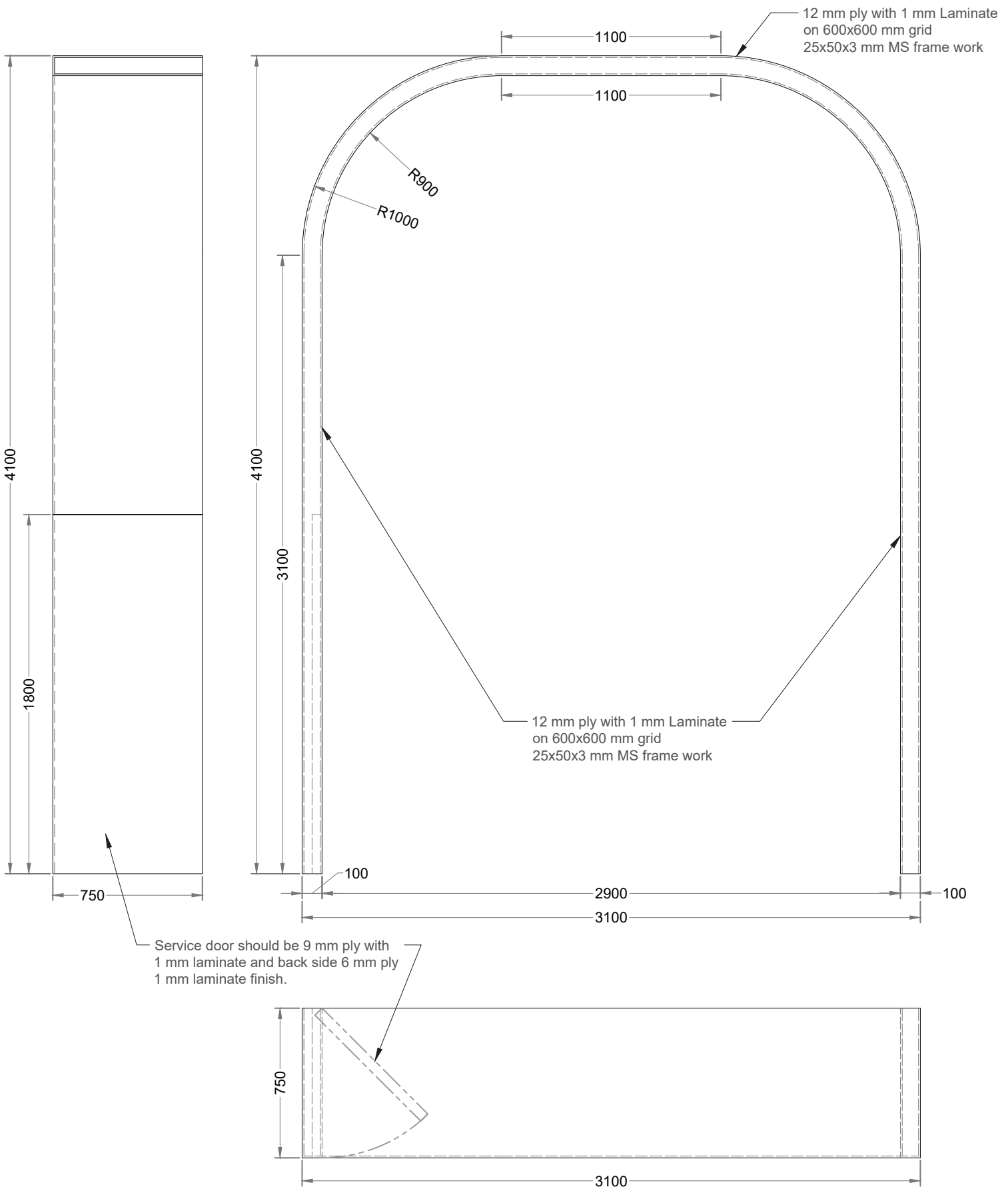

All Dimensions are in m.m.

<b>Creative Museum Designers</b>			
UNIT: Design Section		PROJ: GSI Gwalior Gallery - II	
DRG.NO. CMD-007.12.52.1/EN-1/1	DATE 01/08/2023	SCALE NTS	TOLERANCE
TITLE Gallery - II Entry Gate			NO OFF 02 OFF 02
Drawn By Mr. Pratik Saha	Checked By Mr. Susanta Shaw	Approved By Mr. K. S. Murali	

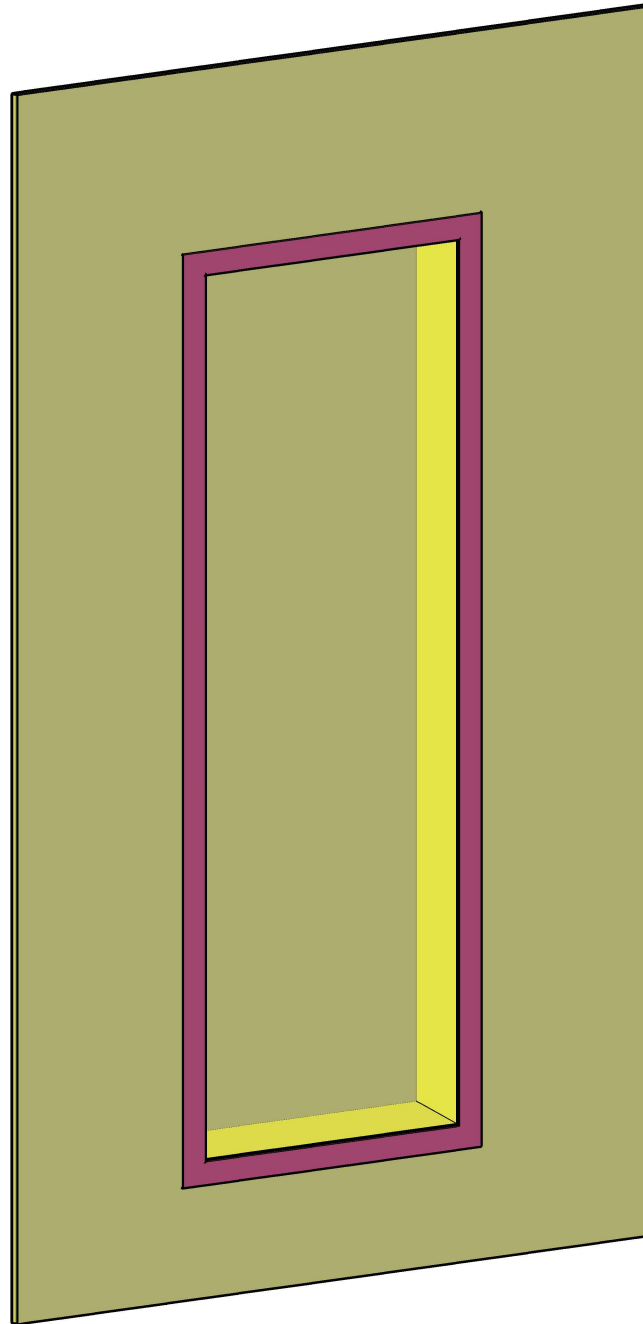

All Dimensions are in m.m.

<b>Creative Museum Designers</b>			
UNIT: Design Section		PROJ: GSI Gwalior Gallery - II	
DRG.NO. CMD-007.12.52.1/EN-1/2	DATE 01/08/2023	SCALE NTS	TOLERANCE
TITLE EX- 1.3			NO OFF 01 OFF 02
Drawn By Mr. Pratik Saha	Checked By Mr. Susanta Shaw	Approved By Mr. K. S. Murali	

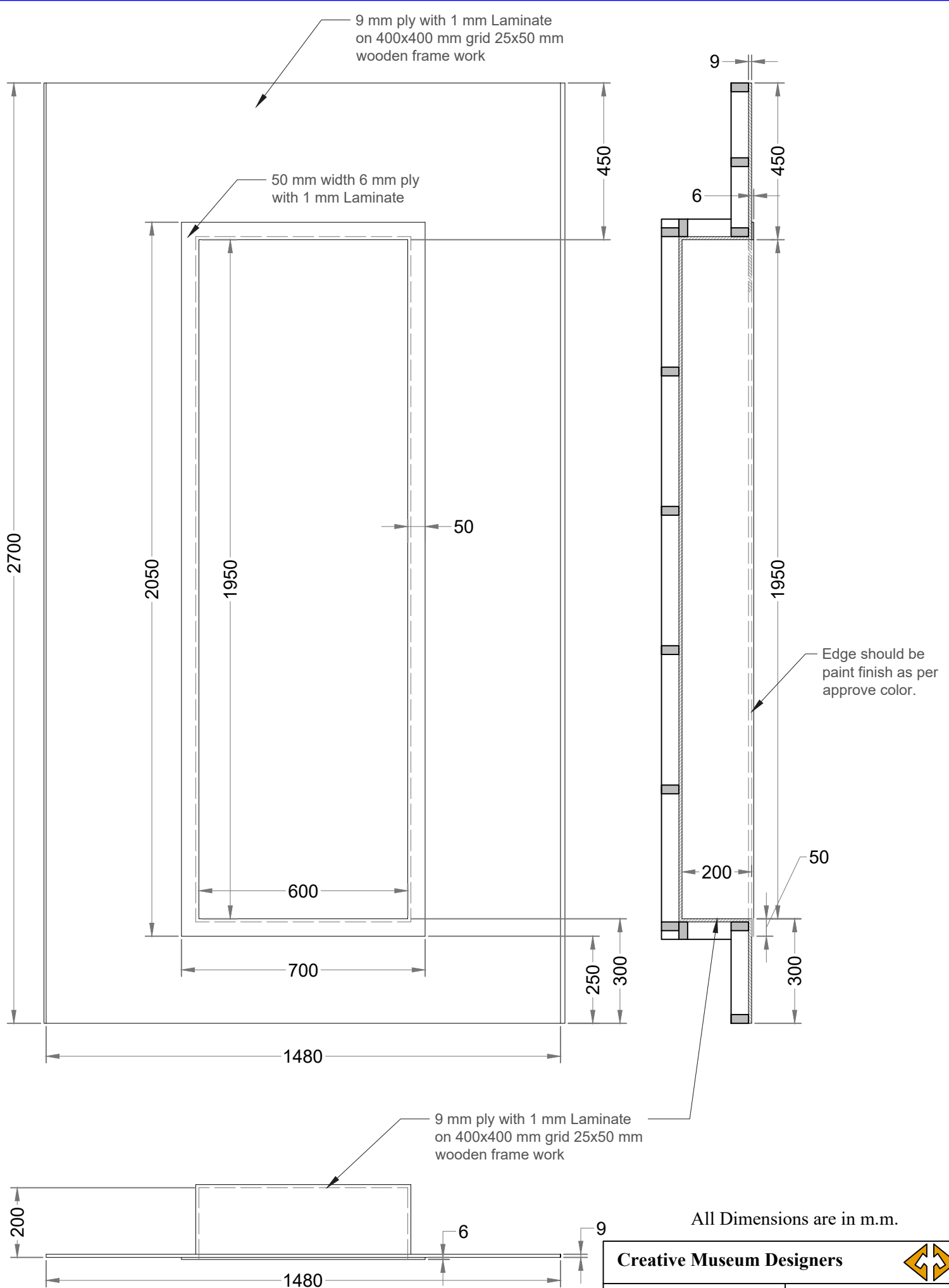

<b>Creative Museum Designers</b>			
UNIT: Design Section		PROJ:GSI Gwalior Gallery - II	
DRG.NO. CMD-007.12.52.1/EN-1/2	DATE 01/08/2023	SCALE NTS	TOLERANCE
TITLE EX-1.3			NO OFF 02 OFF 02
Drawn By Mr. Pratik Saha	Checked By Mr. Susanta Shaw	Approved By Mr. K. S. Murali	

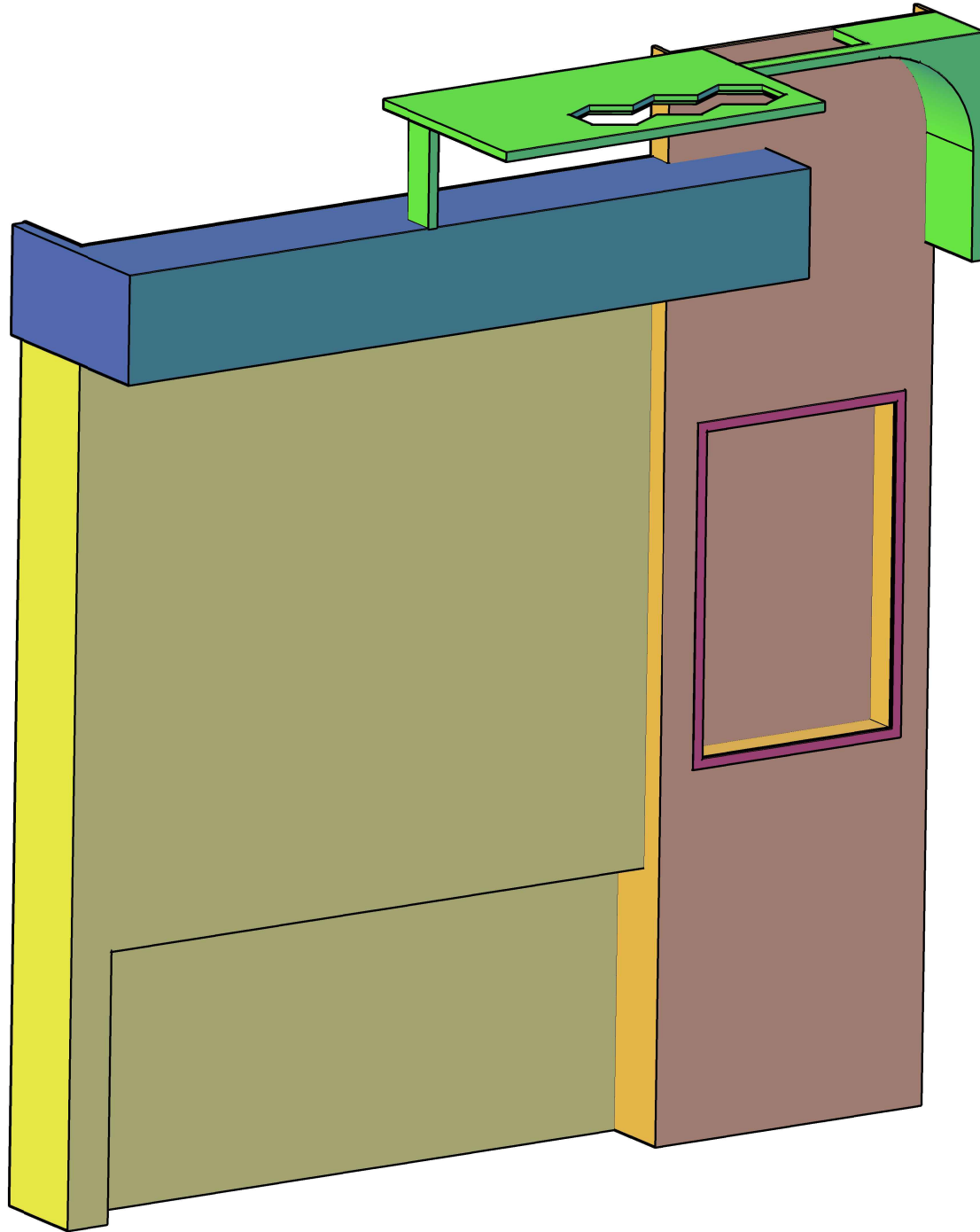

All Dimensions are in m.m.

<b>Creative Museum Designers</b>			
UNIT: Design Section		PROJ: GSI Gwalior Gallery - II	
DRG.NO. CMD-007.12.52.1/EN-1/3	DATE 01/08/2023	SCALE NTS	TOLERANCE
TITLE EX- 1.4			NO OFF 01 OFF 03
Drawn By Mr. Pratik Saha	Checked By Mr. Susanta Shaw	Approved By Mr. K. S. Murali	

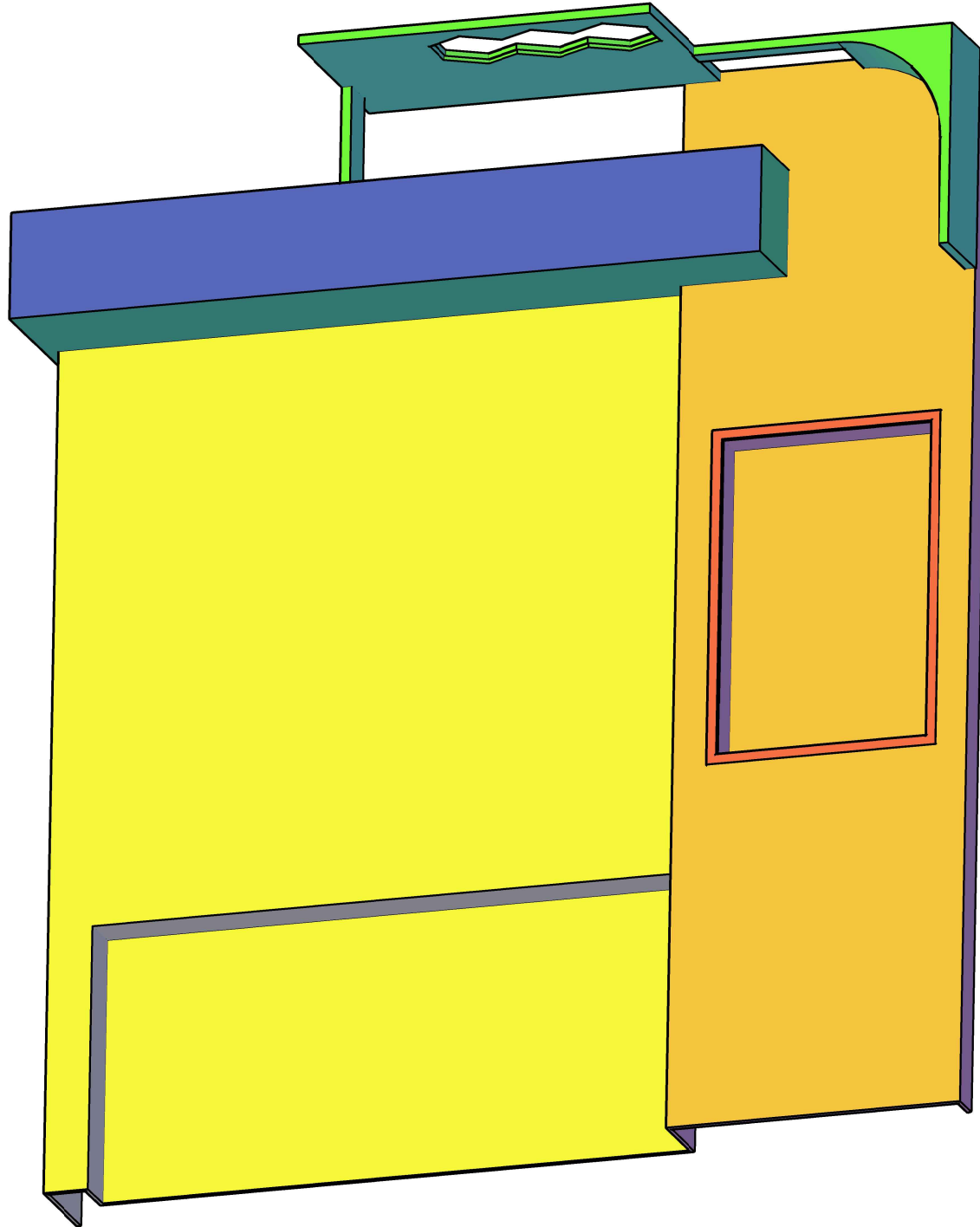

All Dimensions are in m.m.

<b>Creative Museum Designers</b>			
UNIT: Design Section		PROJ: GSI Gwalior Gallery - II	
DRG.NO. CMD-007.12.52.1/EN-1/3	DATE 01/08/2023	SCALE NTS	TOLERANCE
TITLE EX- 1.4			NO OFF 02 OFF 03
Drawn By Mr. Pratik Saha	Checked By Mr. Susanta Shaw	Approved By Mr. K. S. Murali	





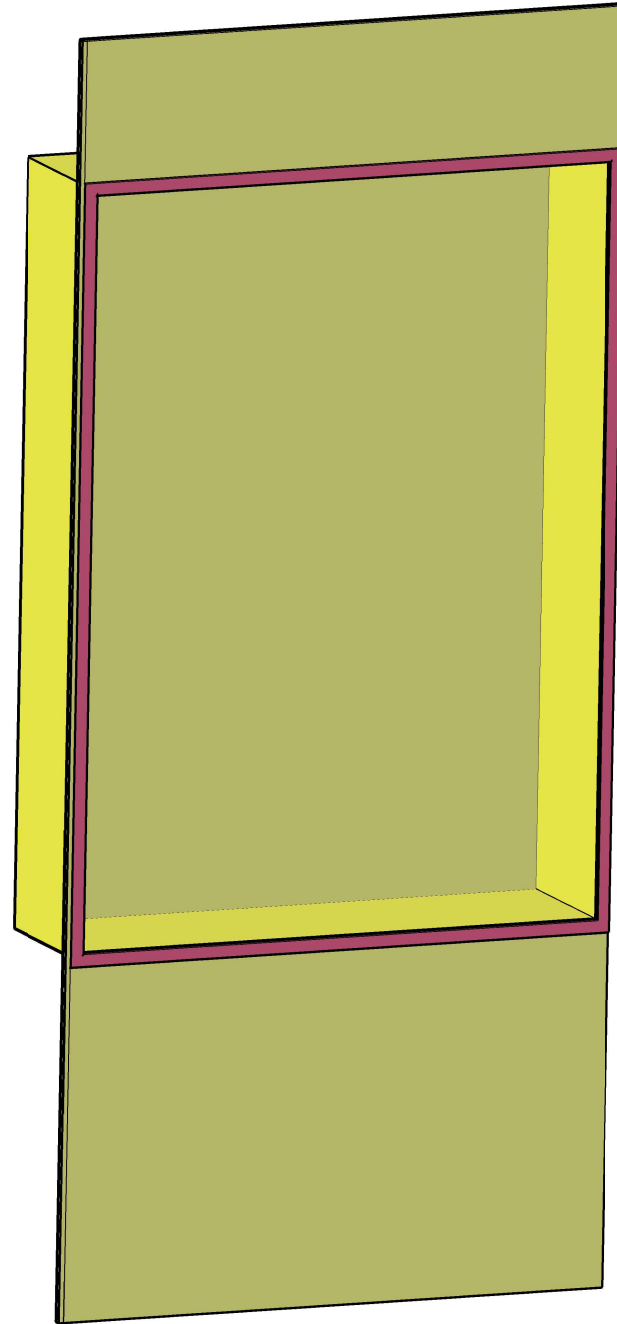

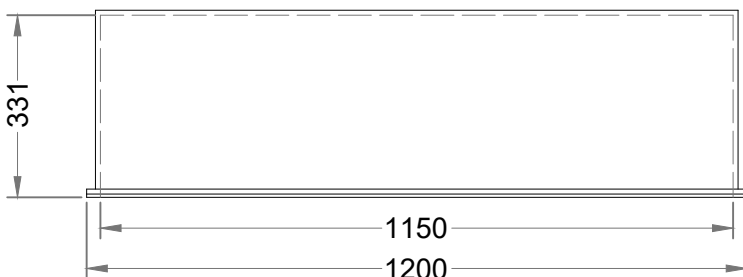
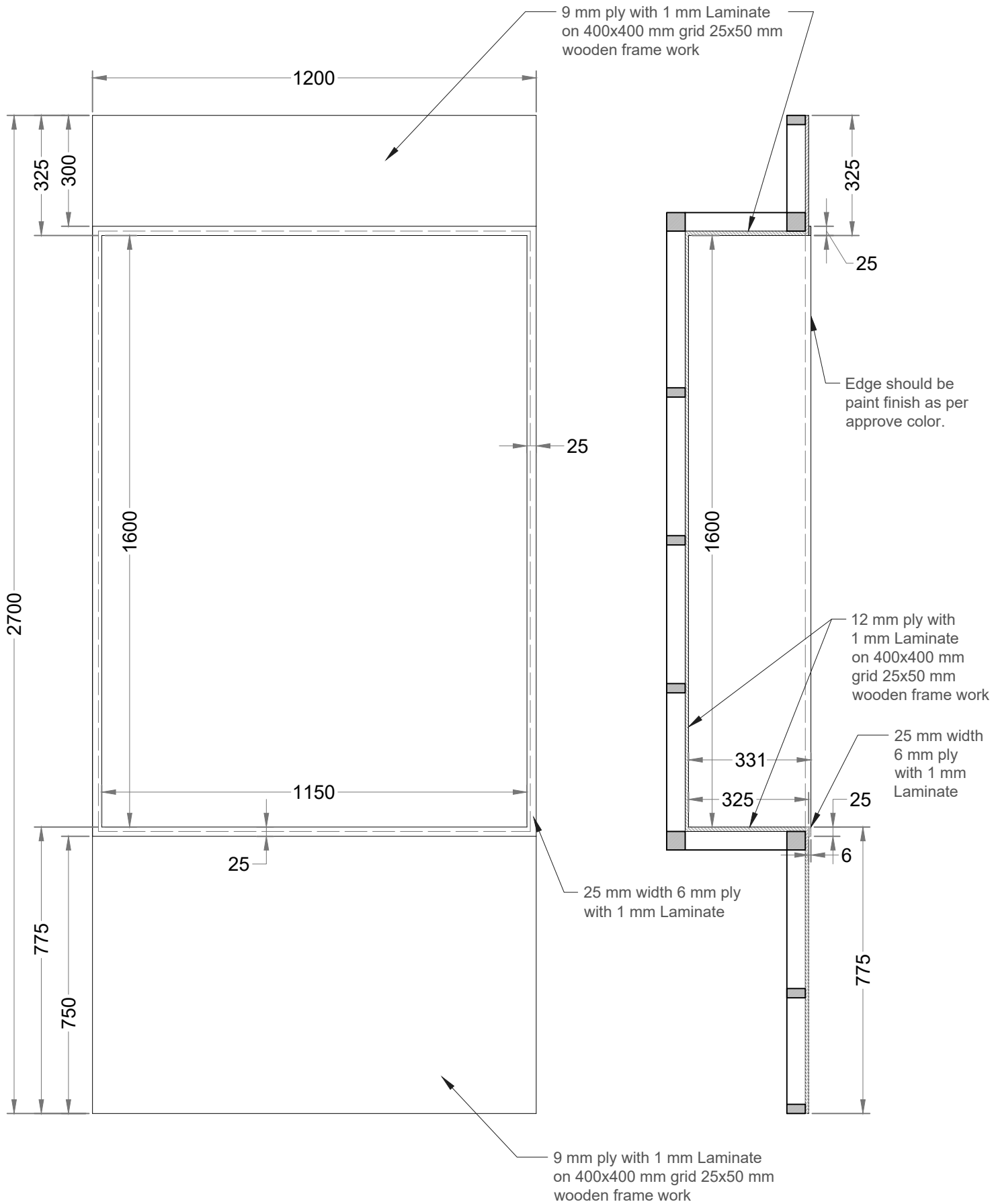

All Dimensions are in m.m.

<b>Creative Museum Designers</b>			
UNIT: Design Section		PROJ: GSI Gwalior Gallery - II	
DRG.NO. CMD-007.12.52.1/EN-1/4	DATE 01/08/2023	SCALE NTS	TOLERANCE
TITLE EX- 1.4			NO OFF 01 OFF 02
Drawn By Mr. Pratik Saha	Checked By Mr. Susanta Shaw	Approved By Mr. K. S. Murali	



All Dimensions are in m.m.

<b>Creative Museum Designers</b>				
UNIT: Design Section		PROJ: GSI Gwalior Gallery - II		
DRG.NO. CMD-007.12.52.1/EN-1/4	DATE 01/08/2023	SCALE NTS	TOLERANCE	
TITLE EX- 1.4			NO OFF 02 OFF 02	
Drawn By Mr. Pratik Saha	Checked By Mr. Susanta Shaw	Approved By Mr. K. S. Murali		

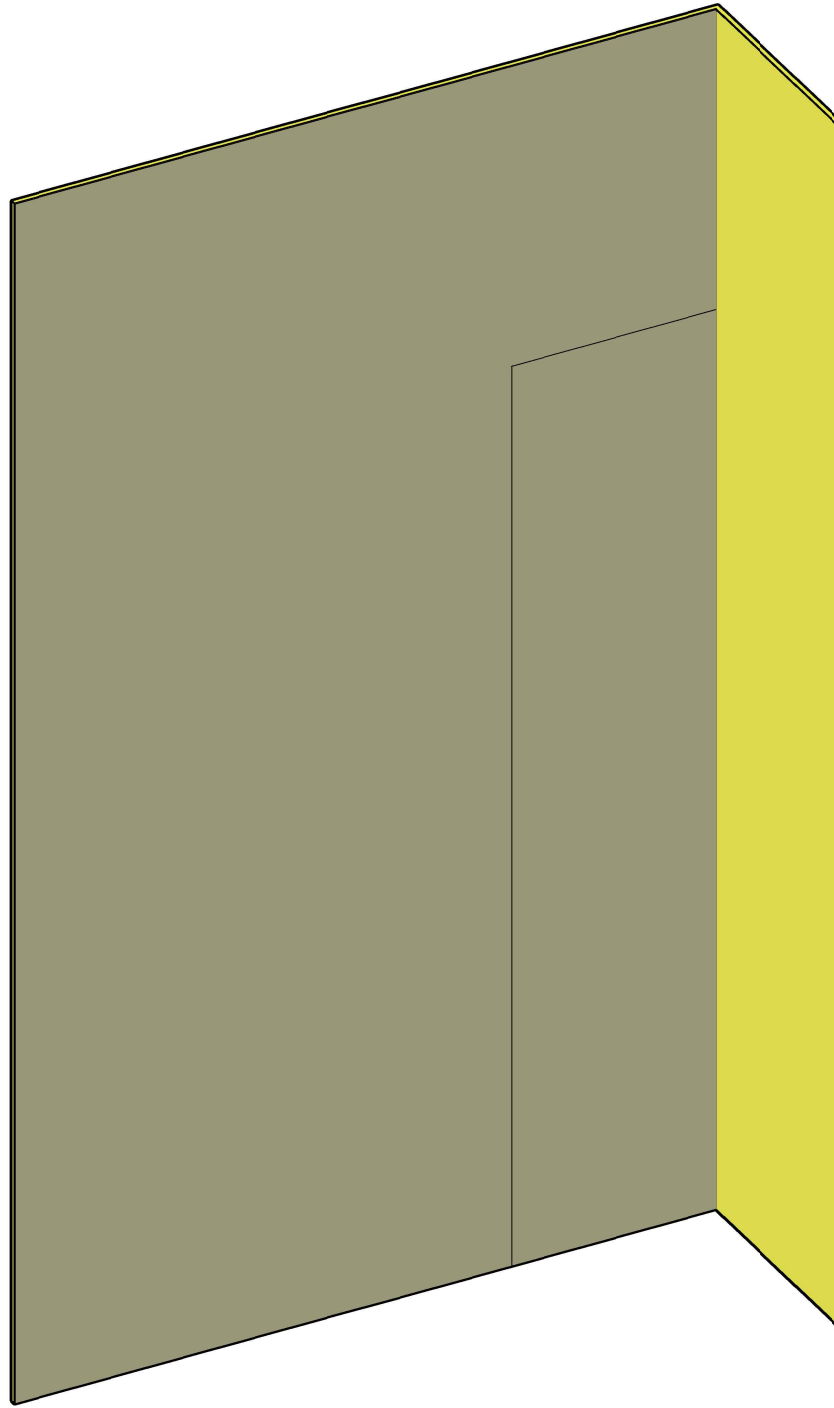

All Dimensions are in m.m.

<b>Creative Museum Designers</b>			
UNIT: Design Section		PROJ: GSI Gwalior Gallery - II	
DRG.NO. CMD-007.12.52.1/EN-1/5	DATE 01/08/2023	SCALE NTS	TOLERANCE
TITLE EX- 1.9			NO OFF 01 OFF 02
Drawn By Mr. Pratik Saha	Checked By Mr. Susanta Shaw	Approved By Mr. K. S. Murali	

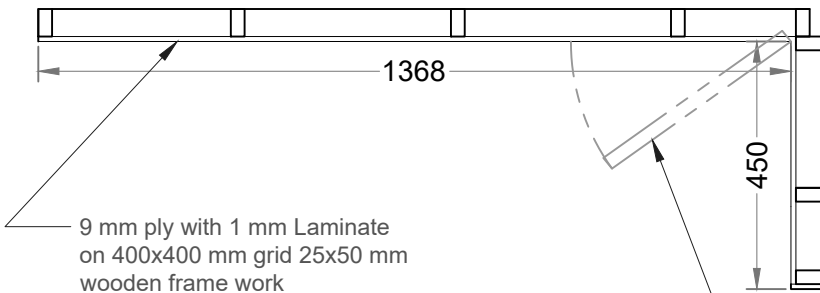
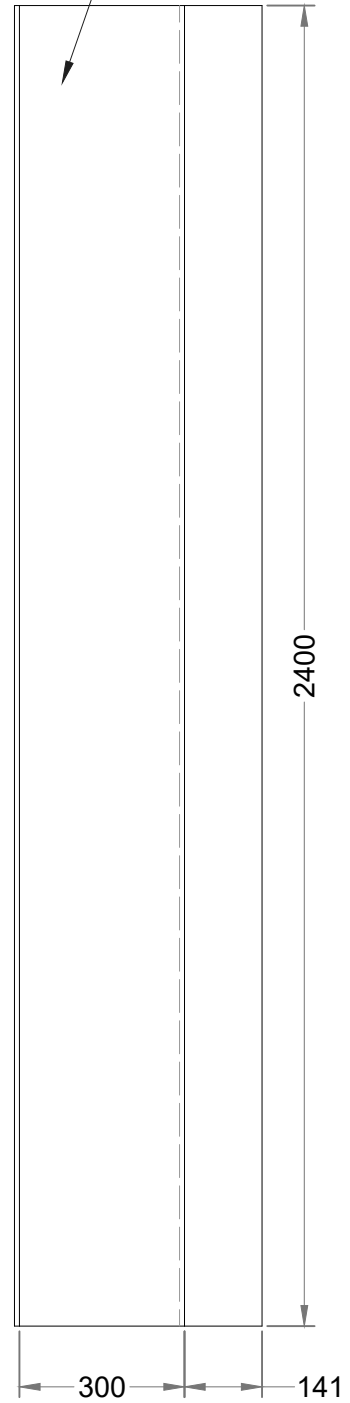
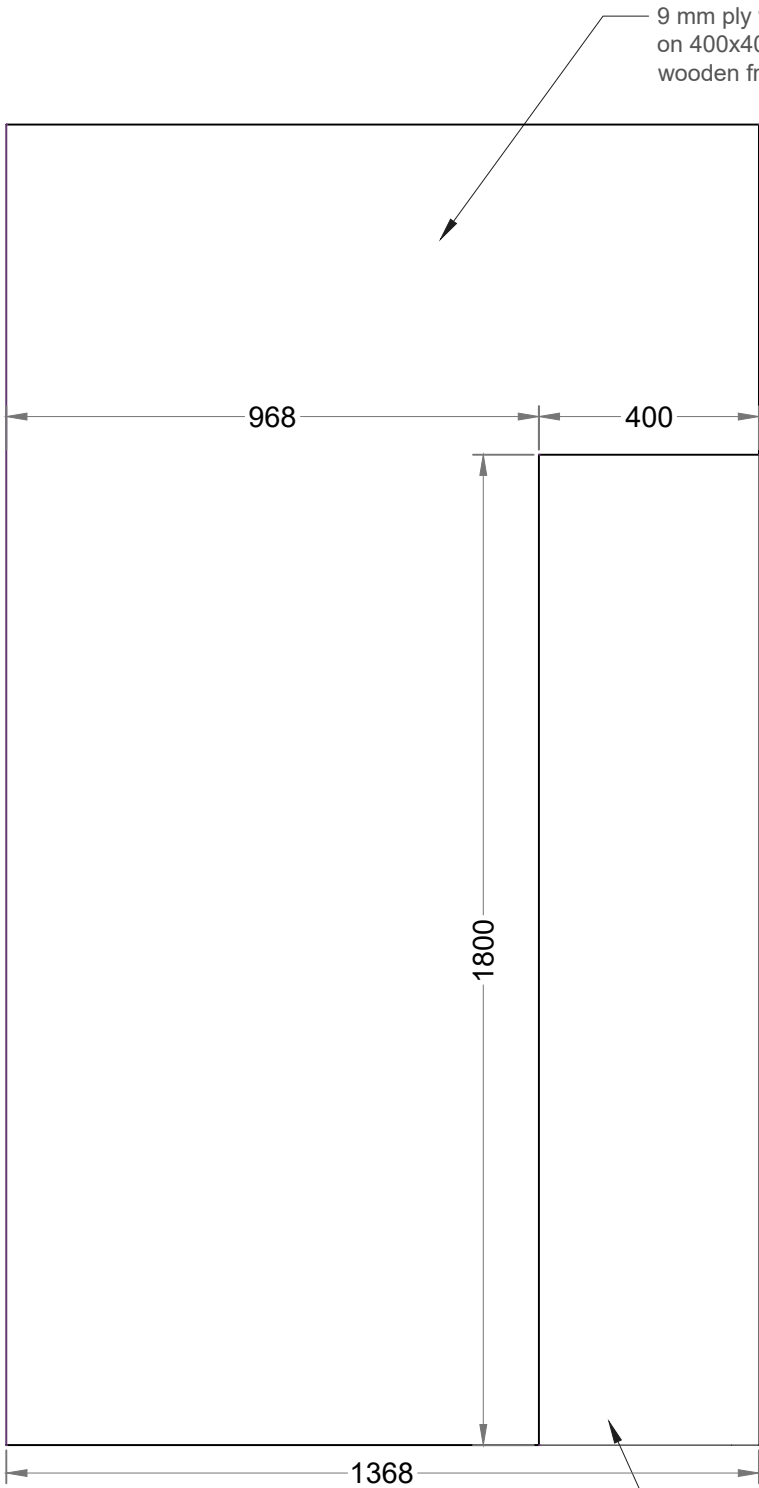

Service door should be 9 mm ply with 1 mm laminate and back side 6 mm ply 1 mm laminate finish.

Service door should be 9 mm ply with 1 mm laminate and back side 6 mm ply 1 mm laminate finish.

All Dimensions are in m.m.

<b>Creative Museum Designers</b>			
UNIT: Design Section		PROJ: GSI Gwalior Gallery - II	
DRG.NO. CMD-007.12.52.1/EN-1/5	DATE 01/08/2023	SCALE NTS	TOLERANCE
TITLE EX- 1.9			NO OFF 02 OFF 02
Drawn By Mr. Pratik Saha	Checked By Mr. Susanta Shaw	Approved By Mr. K. S. Murali	

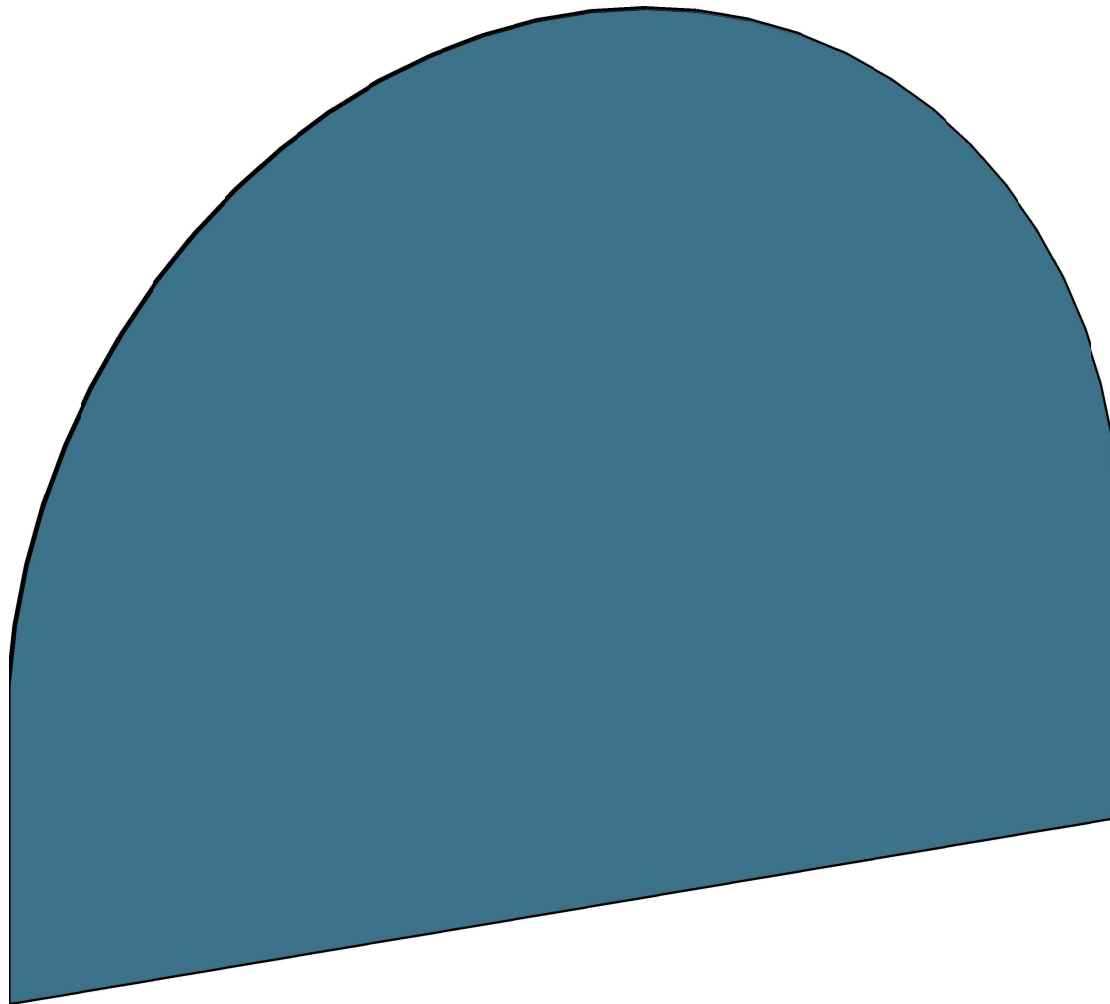

All Dimensions are in m.m.

<b>Creative Museum Designers</b>			
UNIT: Design Section		PROJ: GSI Gwalior Gallery - II	
DRG.NO. CMD-007.12.52.1/EN-2/1	DATE 01/08/2023	SCALE NTS	TOLERANCE
TITLE Ex - 2.1, Ex - 2.2, Ex - 2.3 back arch upper covering			NO OFF 01 OFF 04
Drawn By Mr. Pratik Saha	Checked By Mr. Susanta Shaw	Approved By Mr. K. S. Murali	

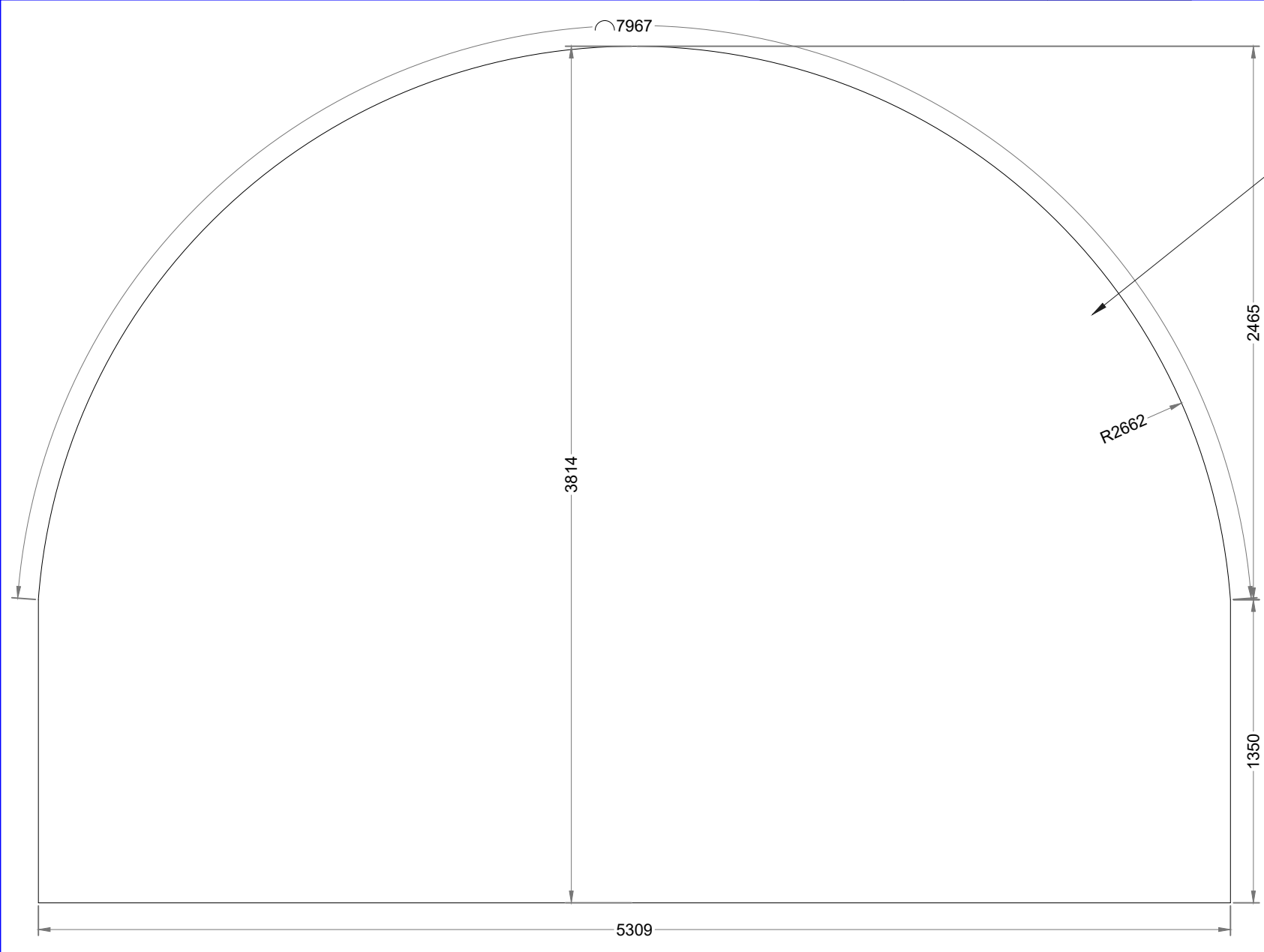

Both side 9 mm ply with 1 mm Laminate on 400x400 mm grid 25x50 mm wooden frame work

N:B:  
Fixed the panel with wooden wedges and adhesives.  
Don't use pins or any permanent grouting materials.

All Dimensions are in m.m.

<b>Creative Museum Designers</b>				
UNIT: Design Section		PROJ: GSI Gwalior Gallery - II		
DRG.NO. CMD-007.12.52.1/EN-2/1	DATE 01/08/2023	SCALE NTS	TOLERANCE	
TITLE Ex - 2.1, Ex - 2.2, Ex - 2.3 back arch upper covering			NO OFF 02 OFF 04	
Drawn By Mr. Pratik Saha	Checked By Mr. Susanta Shaw	Approved By Mr. K. S. Murali		

Please make the boxes as per actual dimension after getting the exhibit & also make a suitable roller arrangement for maintenance

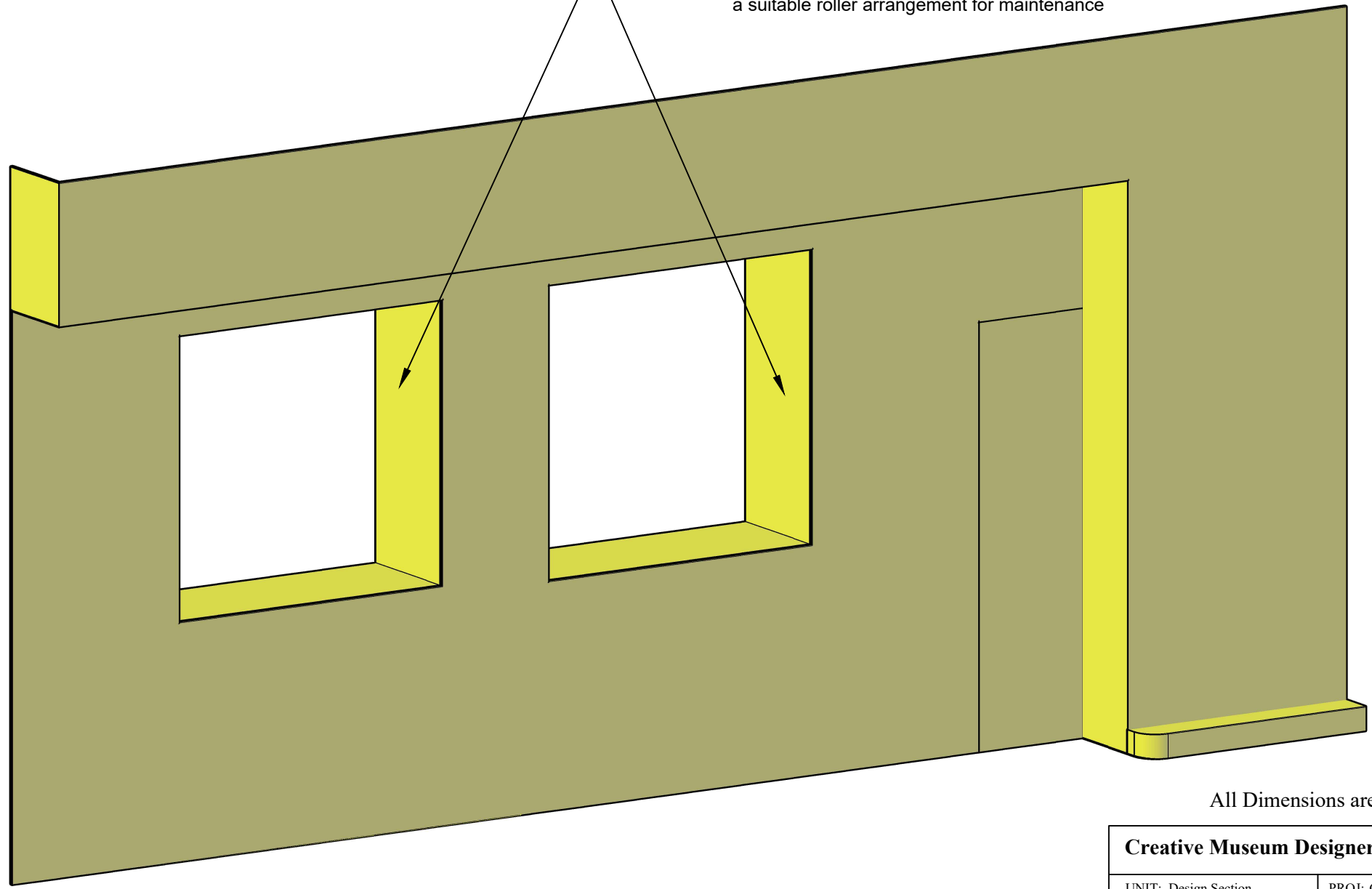

All Dimensions are in m.m.

<b>Creative Museum Designers</b>			
UNIT: Design Section		PROJ: GSI Gwalior Gallery - II	
DRG.NO. CMD-007.12.52.1/EN-2/1	DATE 01/08/2023	SCALE NTS	TOLERANCE
TITLE Ex - 2.1, Ex - 2.2, Ex - 2.3			NO OFF 03 OFF 04
Drawn By Mr. Pratik Saha	Checked By Mr. Susanta Shaw	Approved By Mr. K. S. Murali	



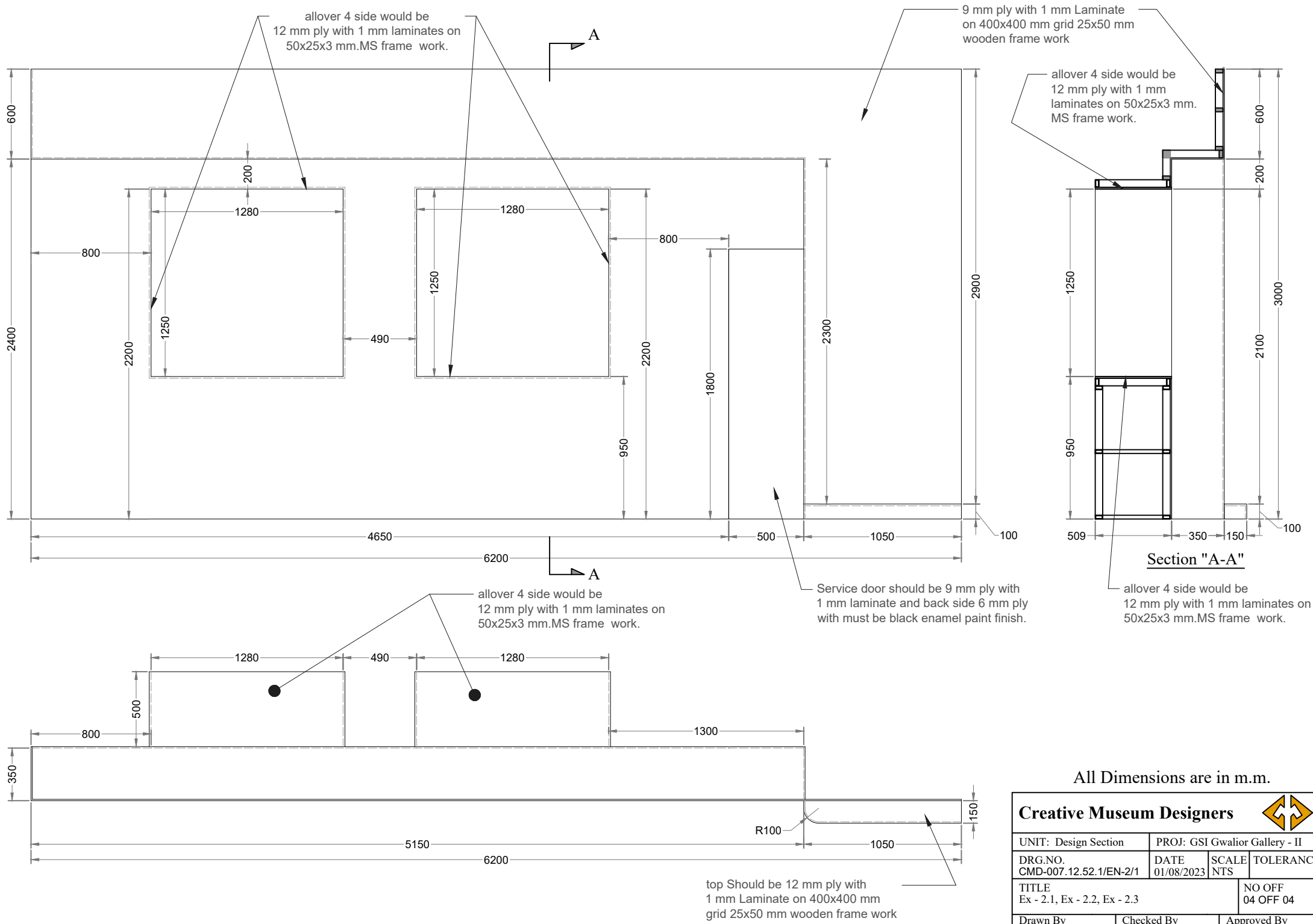

All Dimensions are in m.m.

<b>Creative Museum Designers</b>				
UNIT: Design Section	PROJ: GSI Gwalior Gallery - II			
DRG.NO. CMD-007.12.52.1/EN-2/1	DATE 01/08/2023	SCALE NTS	TOLERANCE	
TITLE Ex - 2.1, Ex - 2.2, Ex - 2.3			NO OFF 04 OFF 04	
Drawn By Mr. Pratik Saha	Checked By Mr. Susanta Shaw	Approved By Mr. K. S. Murali		

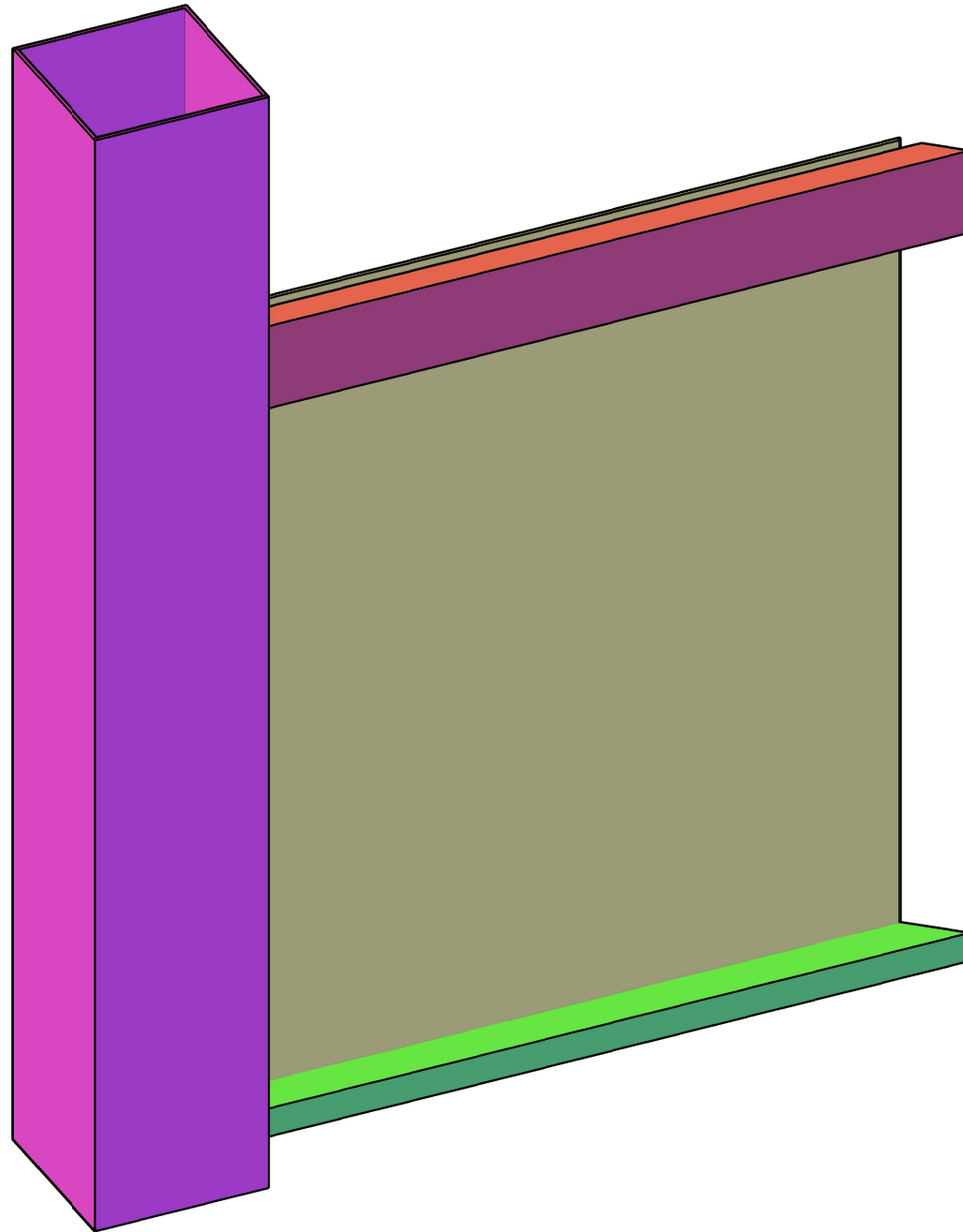

All Dimensions are in m.m.

<b>Creative Museum Designers</b>			
UNIT: Design Section		PROJ: GSI Gwalior Gallery - II	
DRG.NO. CMD-007.12.52.1/EN-2/2	DATE 01/08/2023	SCALE NTS	TOLERANCE
TITLE Ex - 2.4, Ex - 2.7			NO OFF 01 OFF 03
Drawn By Mr. Pratik Saha	Checked By Mr. Susanta Shaw	Approved By Mr. K. S. Murali	



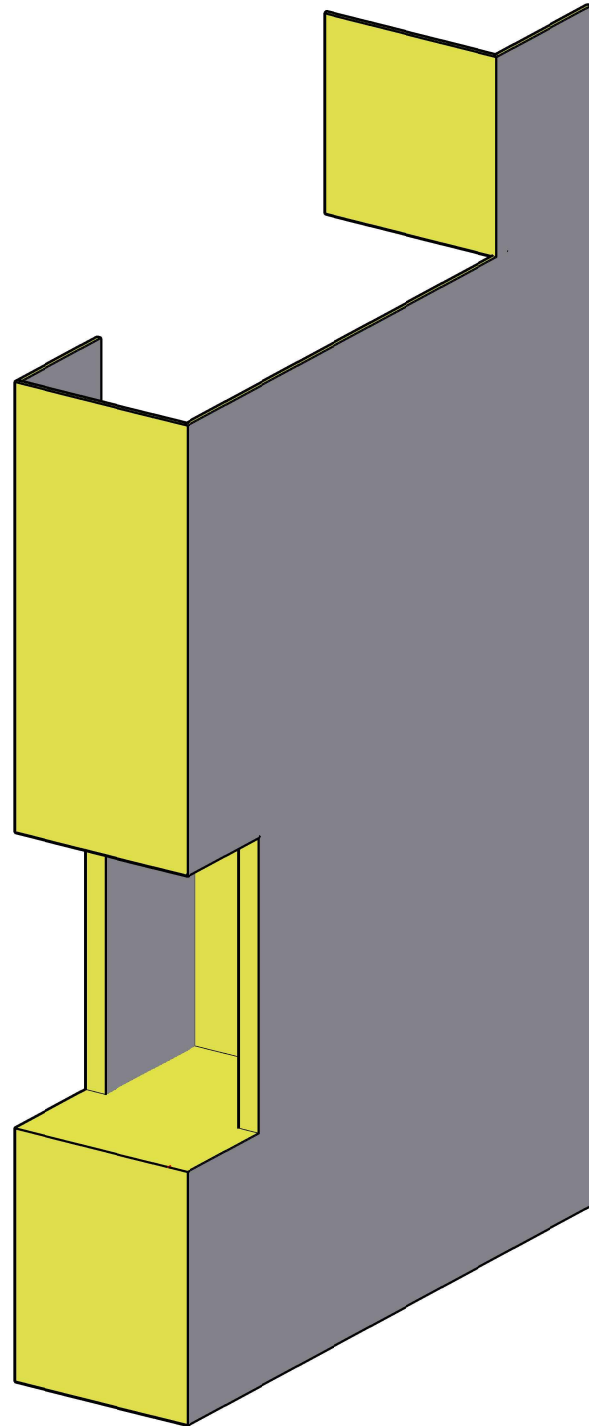

All Dimensions are in m.m.

<b>Creative Museum Designers</b>			
UNIT: Design Section		PROJ: GSI Gwalior Gallery - II	
DRG.NO. CMD-007.12.52.1/EN-2/3	DATE 01/08/2023	SCALE NTS	TOLERANCE
TITLE EX- 2.10			NO OFF 01 OFF 02
Drawn By Mr. Pratik Saha	Checked By Mr. Susanta Shaw	Approved By Mr. K. S. Murali	

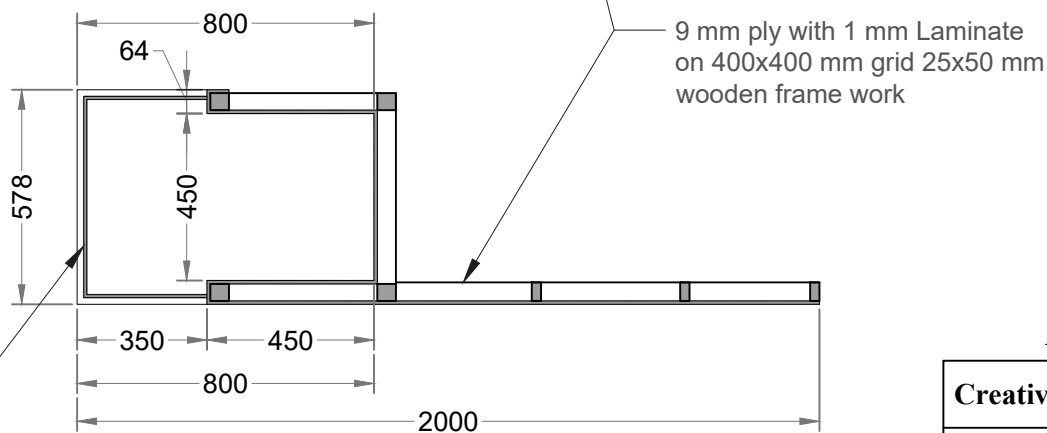
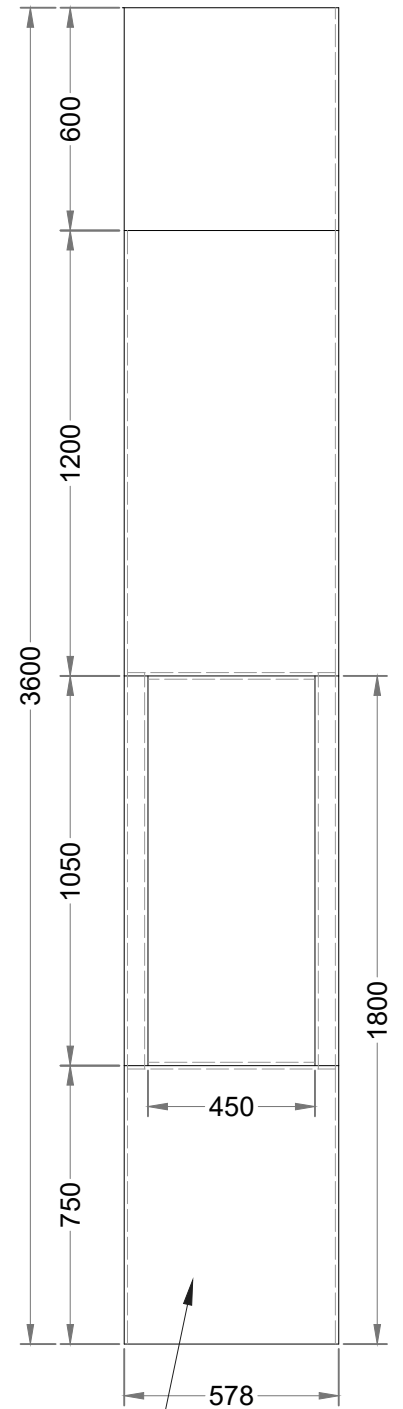
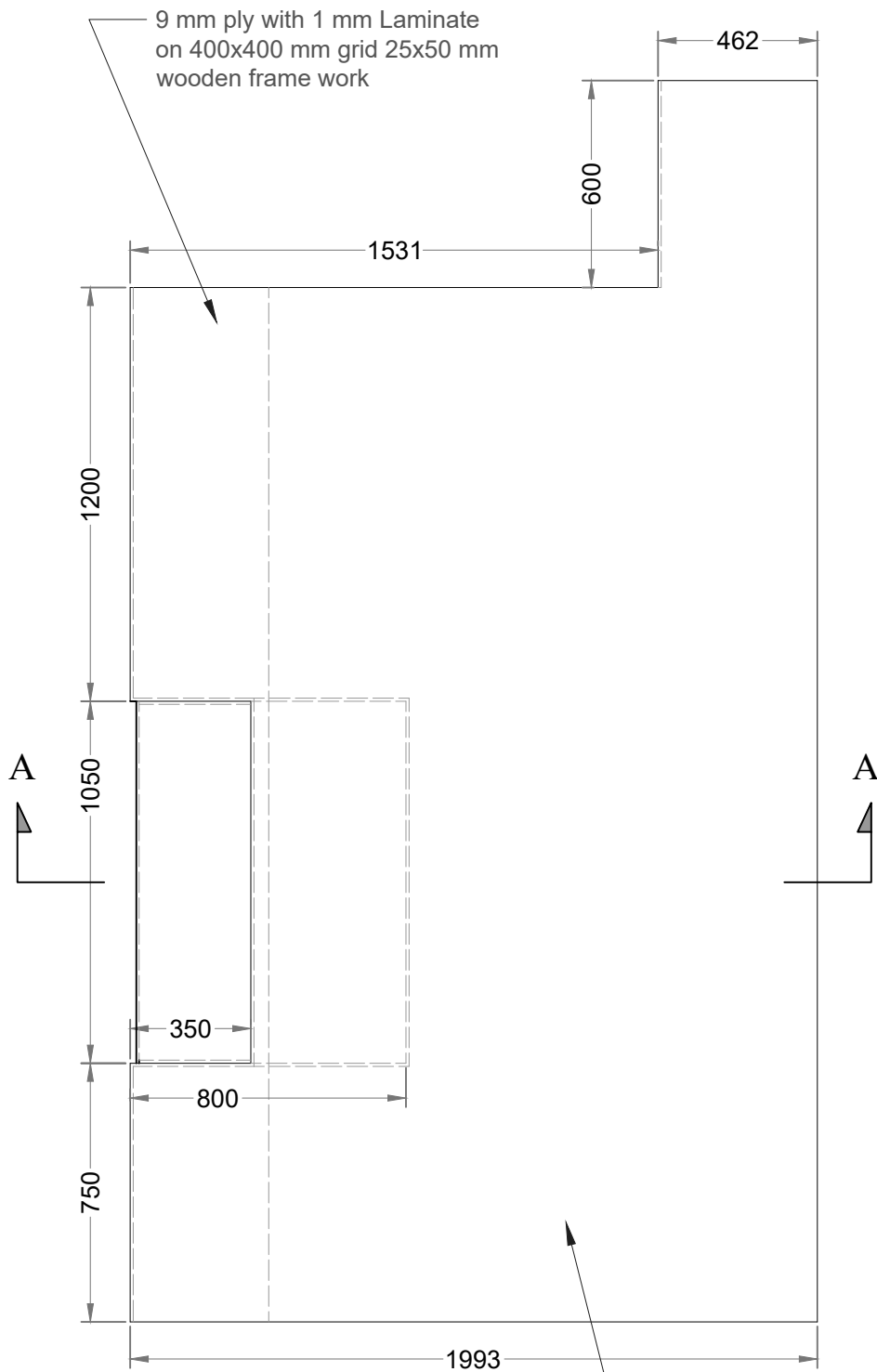

8 mm toughened glassal

**Section "A-A"**

All Dimensions are in m.m.

<b>Creative Museum Designers</b>			
UNIT: Design Section	PROJ: GSI Gwalior Gallery - II		
DRG.NO. CMD-007.12.52.1/EN-2/3	DATE 01/08/2023	SCALE NTS	TOLERANCE
TITLE Ex - 2.10			NO OFF 02 OFF 02
Drawn By Mr. Pratik Saha	Checked By Mr. Susanta Shaw	Approved By Mr. K. S. Murali	

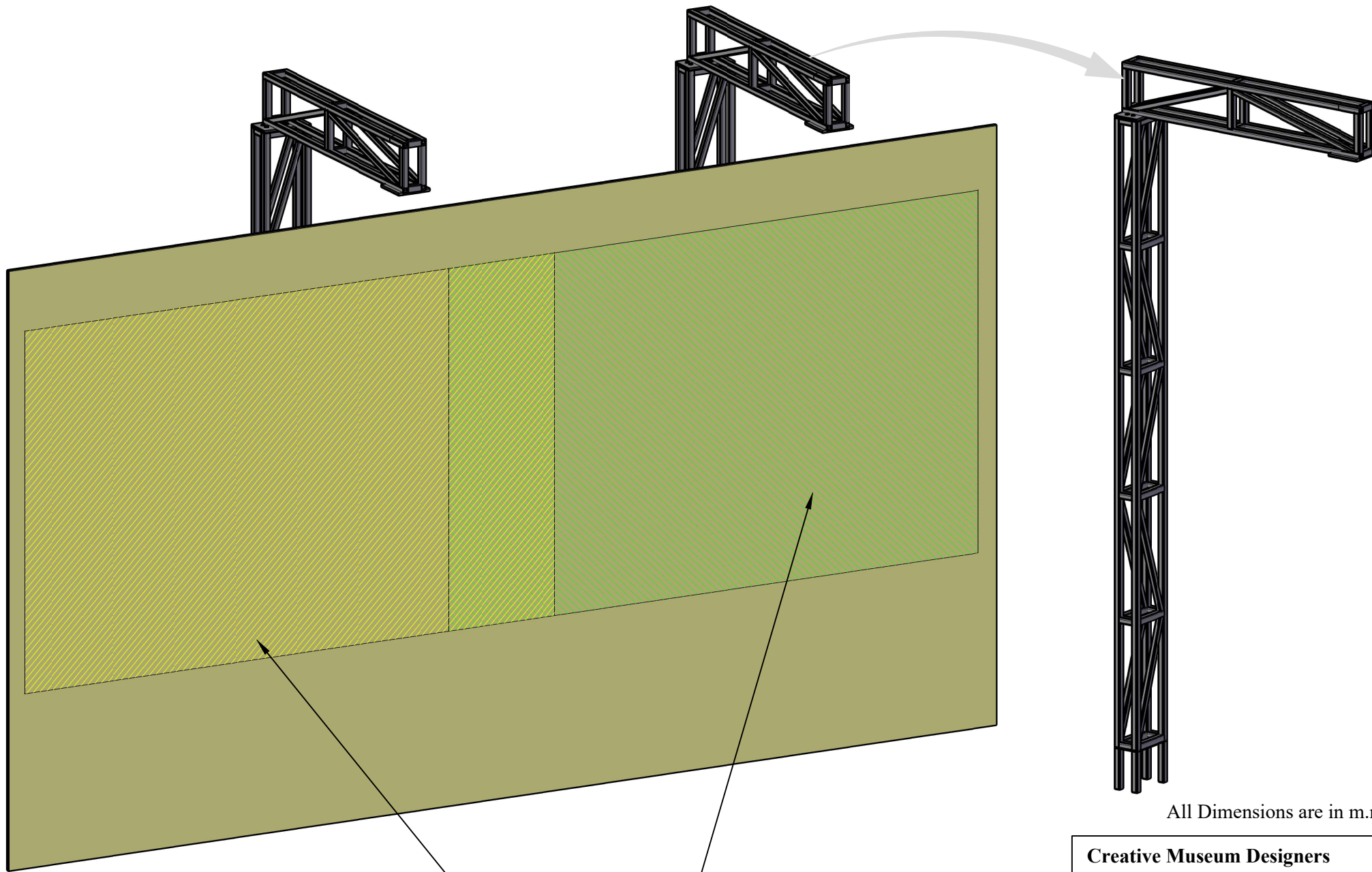

Projection Area

All Dimensions are in m.m.

<b>Creative Museum Designers</b>			
UNIT: Design Section		PROJ: GSI Gwalior Gallery - II	
DRG.NO. CMD-007.12.52.1/EN-3/1	DATE 01/08/2023	SCALE NTS	TOLERANCE
TITLE Ex - 3.3, Ex - 3.4			NO OFF 01 OFF 03
Drawn By Mr. Pratik Saha	Checked By Mr. Susanta Shaw	Approved By Mr. K. S. Murali	

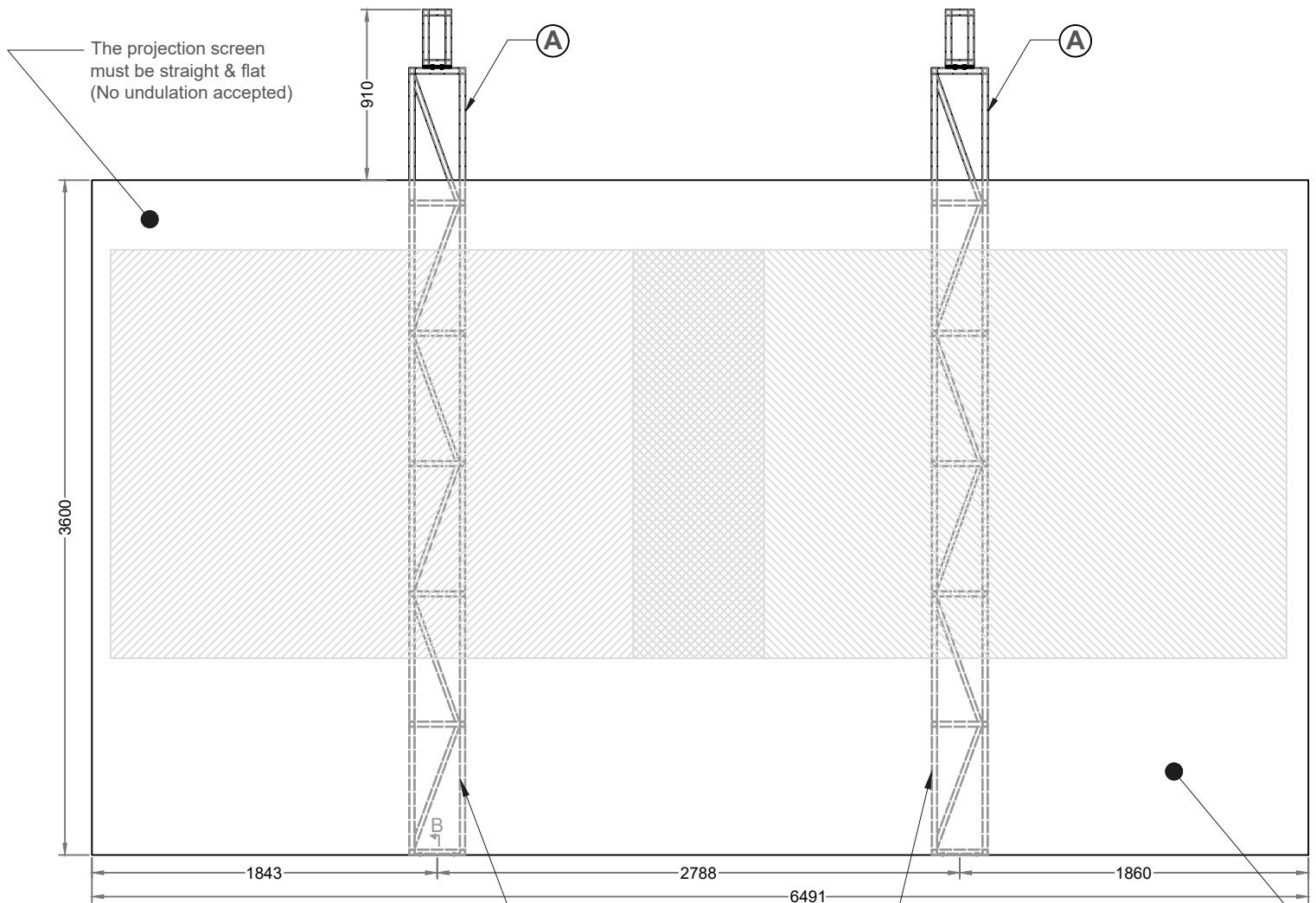

The projection screen must be straight & flat (No undulation accepted)

A

A

B

Two post must be firmly fixed & well Grouted as per site requirement

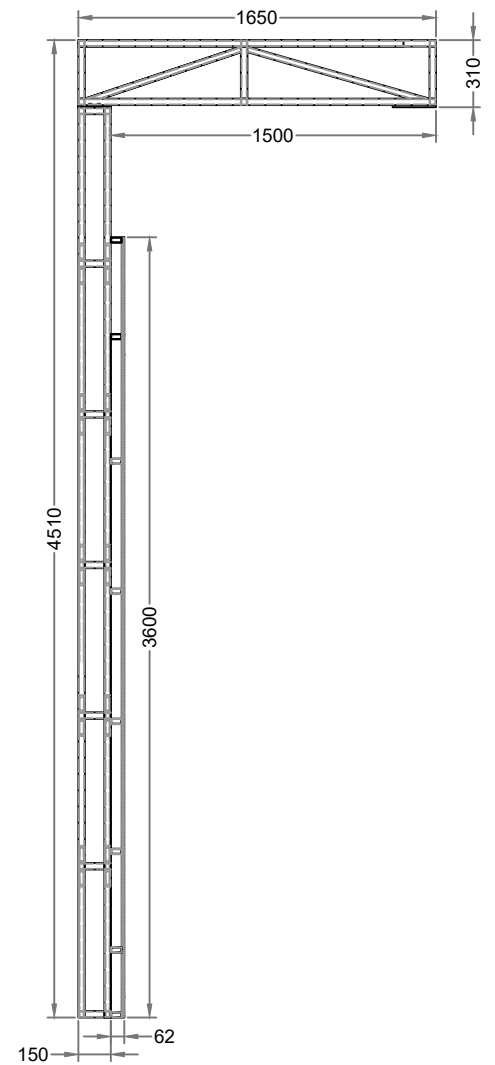

12 mm ply with 1 mm Laminate on 600x600 mm grid 25x50x3 mm Aluminum tube frame work

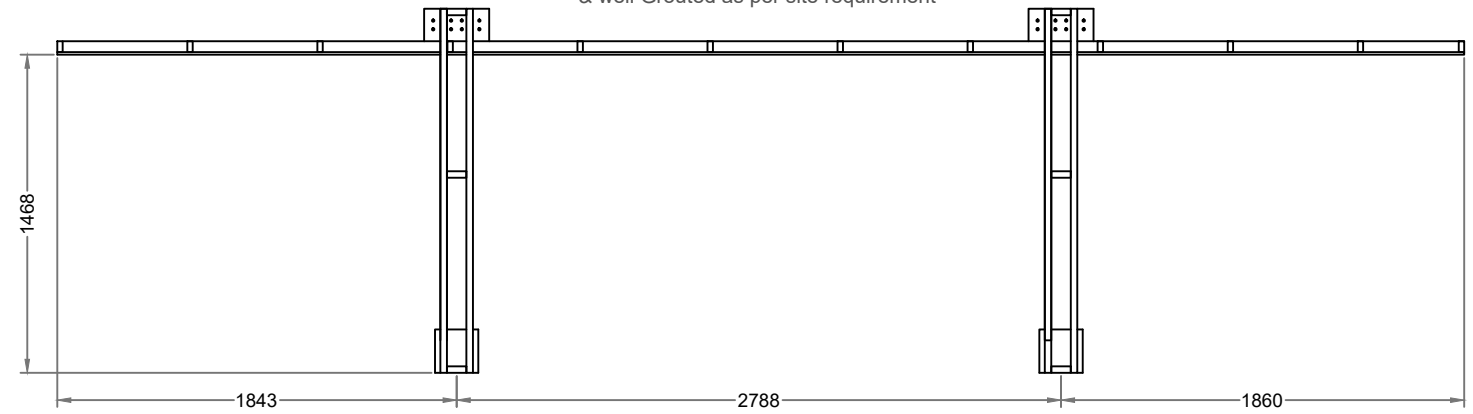

All Dimensions are in m.m.

<b>Creative Museum Designers</b>				
UNIT: Design Section		PROJ: GSI Gwalior Gallery - II		
DRG.NO. CMD-007.12.52.1/EN-3/1	DATE 01/08/2023	SCALE NTS	TOLERANCE 02 OFF 03	
TITLE Ex - 3.3, Ex - 3.4			NO OFF 02 OFF 03	
Drawn By Mr. Pratik Saha	Checked By Mr. Susanta Shaw	Approved By Mr. K. S. Murali		

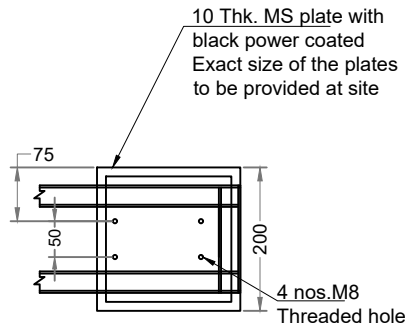
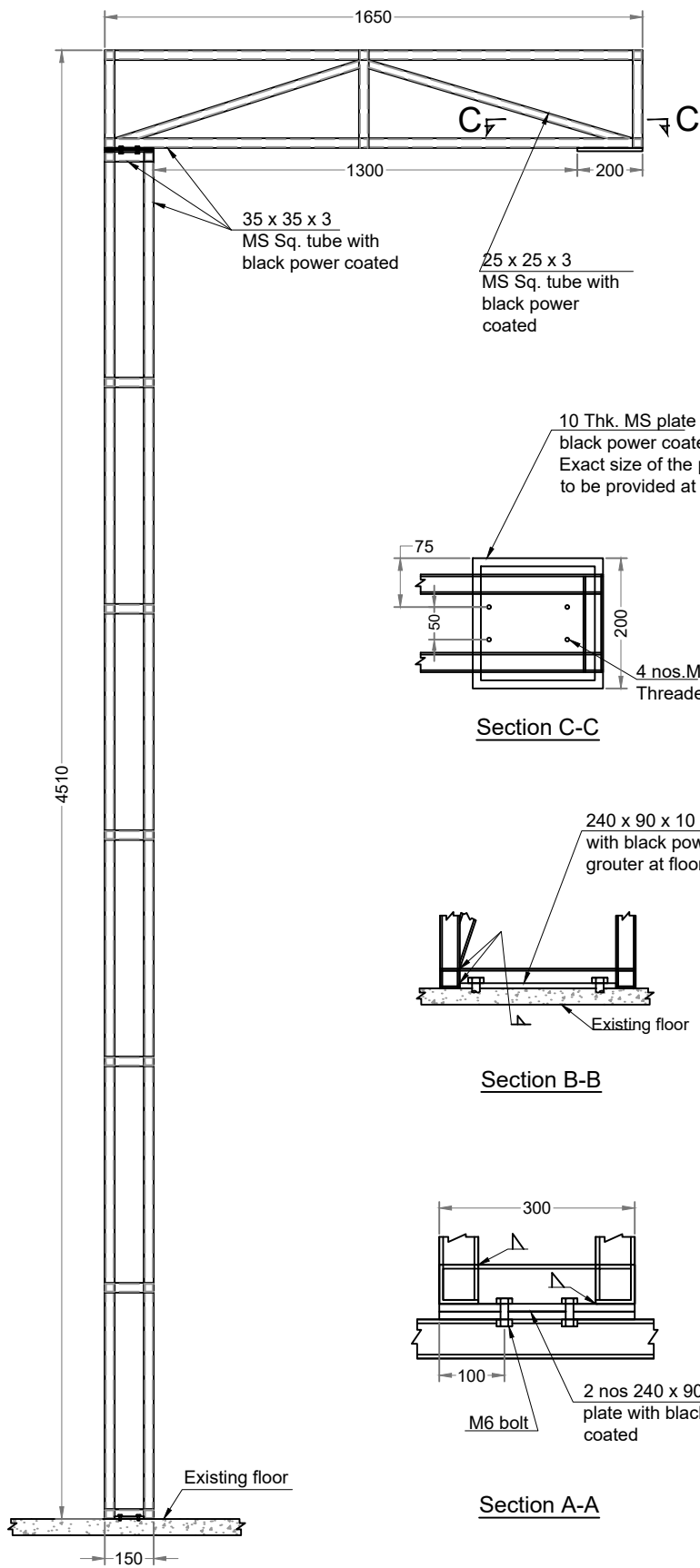

Section C-C

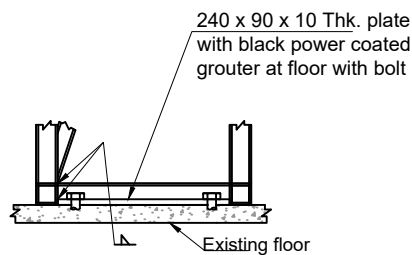

Section B-B

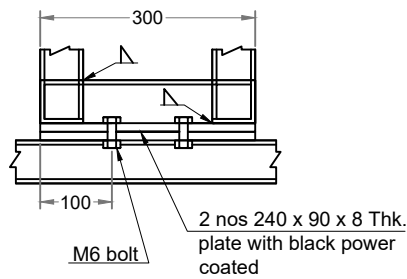

Section A-A

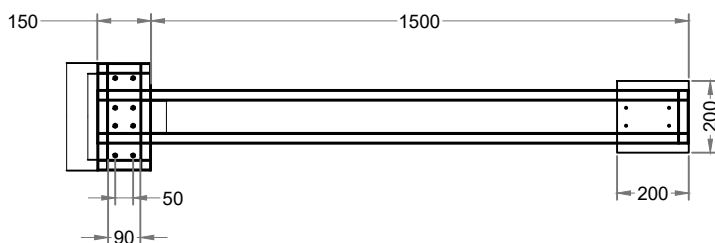
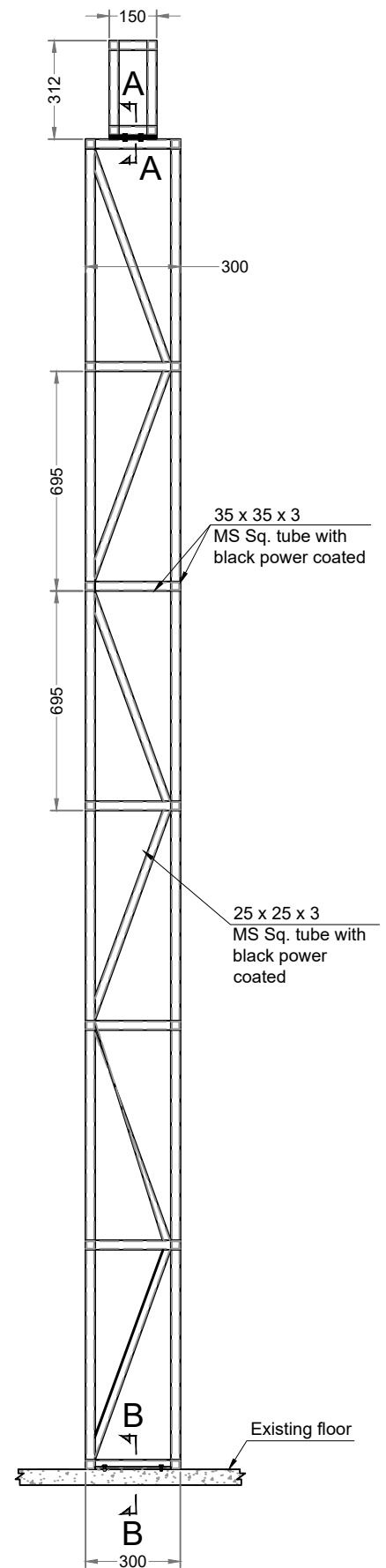

All Dimensions are in m.m.

<b>Creative Museum Designers</b> 			
UNIT: Design Section	PROJ: GSI Gwalior Gallery - II		
DRG.NO. CMD-007.12.52.1/EN-3/1	DATE 01/08/2023	SCALE NTS	TOLERANCE
TITLE Ex - 3.3, Ex - 3.4			NO OFF 03 OFF 03
Drawn By Mr. Pratik Saha	Checked By Mr. Susanta Shaw	Approved By Mr. K. S. Murali	



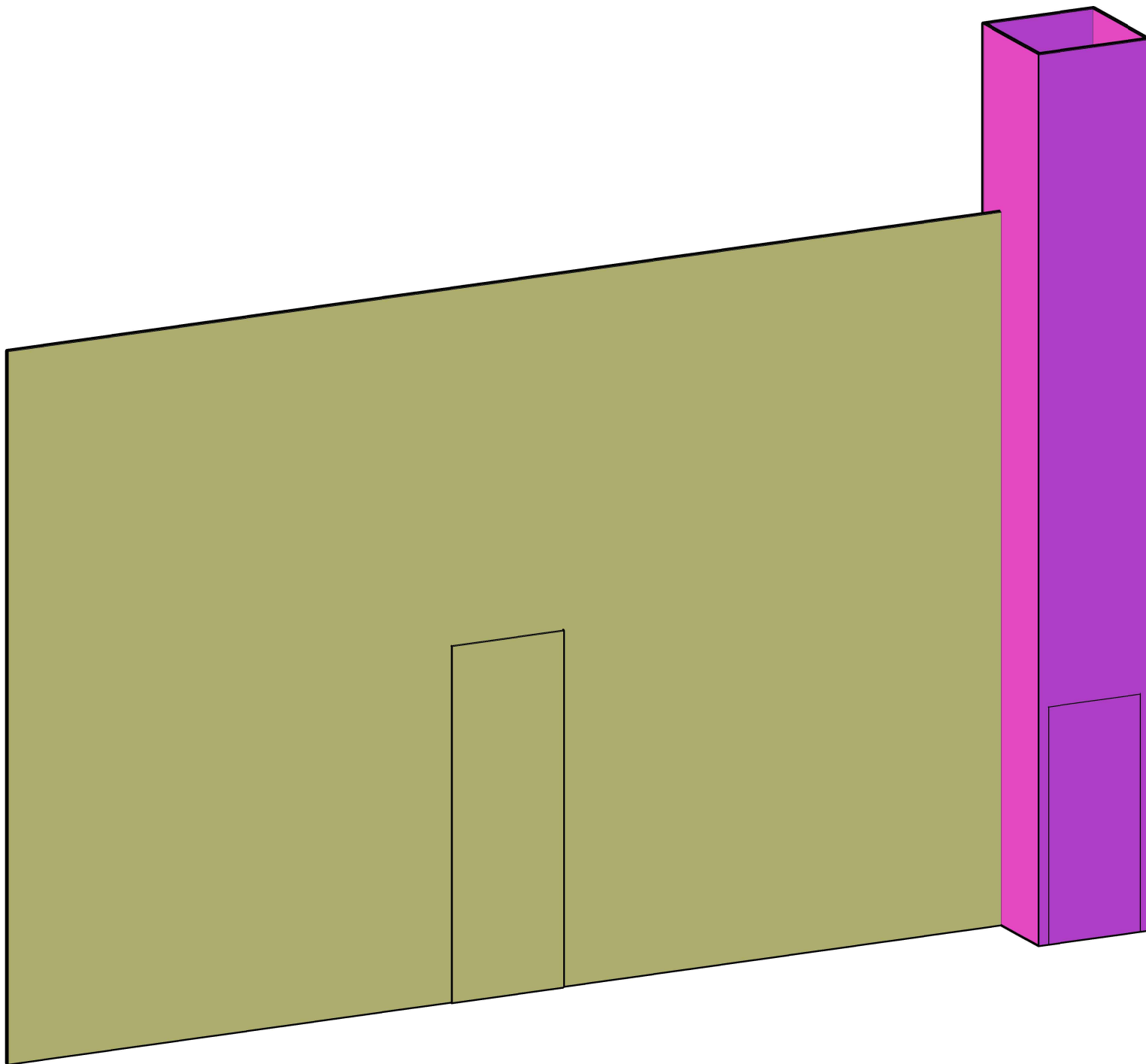

All Dimensions are in m.m.

<b>Creative Museum Designers</b>			
UNIT: Design Section		PROJ: GSI Gwalior Gallery - II	
DRG.NO. CMD-007.12.52.1/EN-3/2	DATE 01/08/2023	SCALE NTS	TOLERANCE
TITLE Ex - 3.4, Ex - 3.5			NO OFF 01 OFF 02
Drawn By Mr. Pratik Saha	Checked By Mr. Susanta Shaw	Approved By Mr. K. S. Murali	

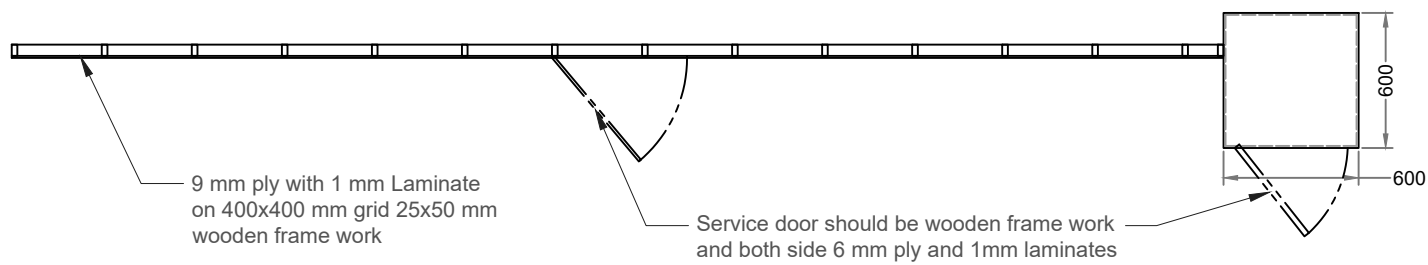
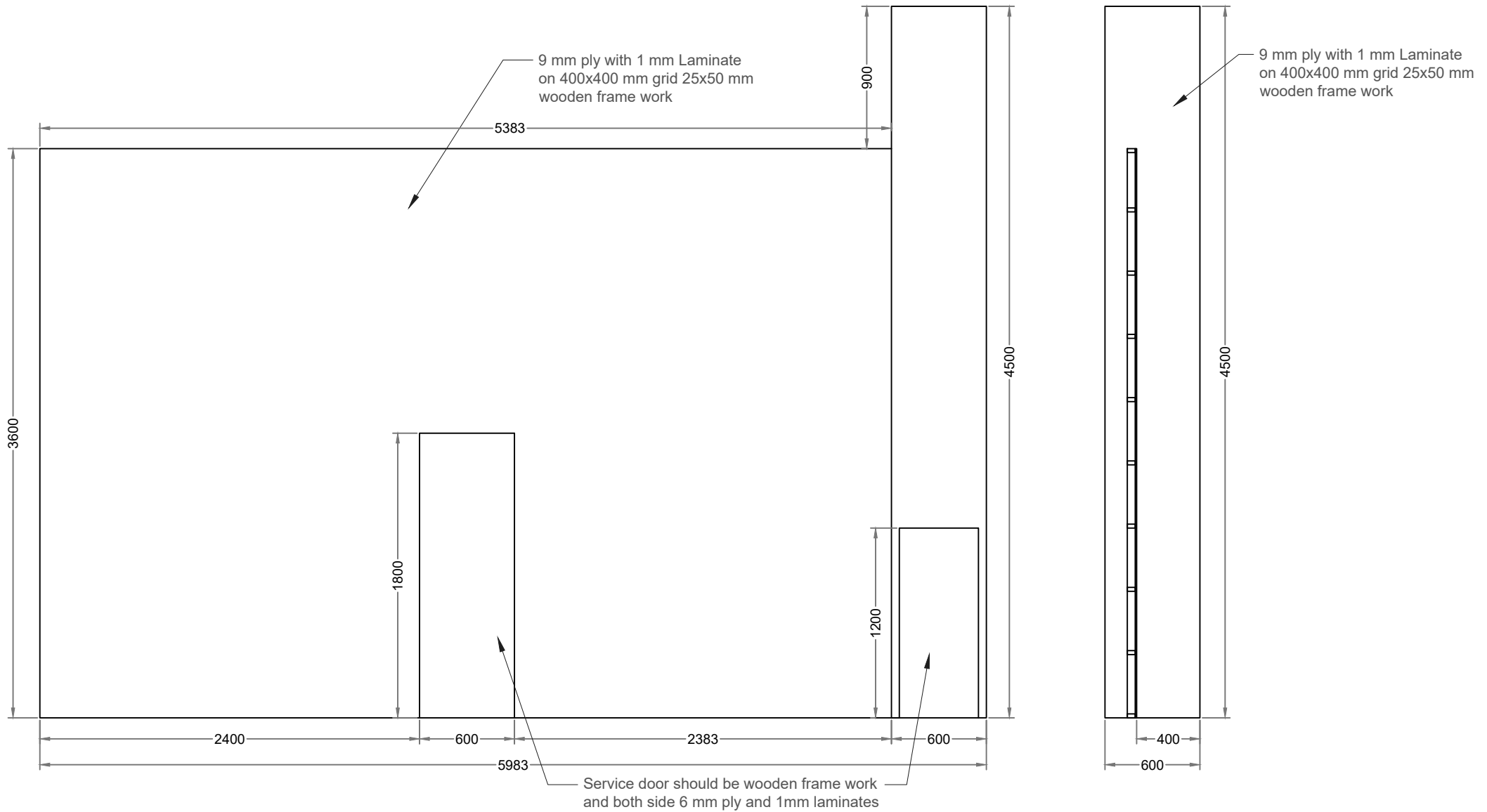

All Dimensions are in m.m.

<b>Creative Museum Designers</b>				
UNIT: Design Section	PROJ: GSI Gwalior Gallery - II			
DRG.NO. CMD-007.12.52.1/EN-3/2	DATE 01/08/2023	SCALE NTS	TOLERANCE	
TITLE Ex - 3.4, Ex - 3.5			NO OFF 02 OFF 02	
Drawn By Mr. Pratik Saha	Checked By Mr. Susanta Shaw	Approved By Mr. K. S. Murali		

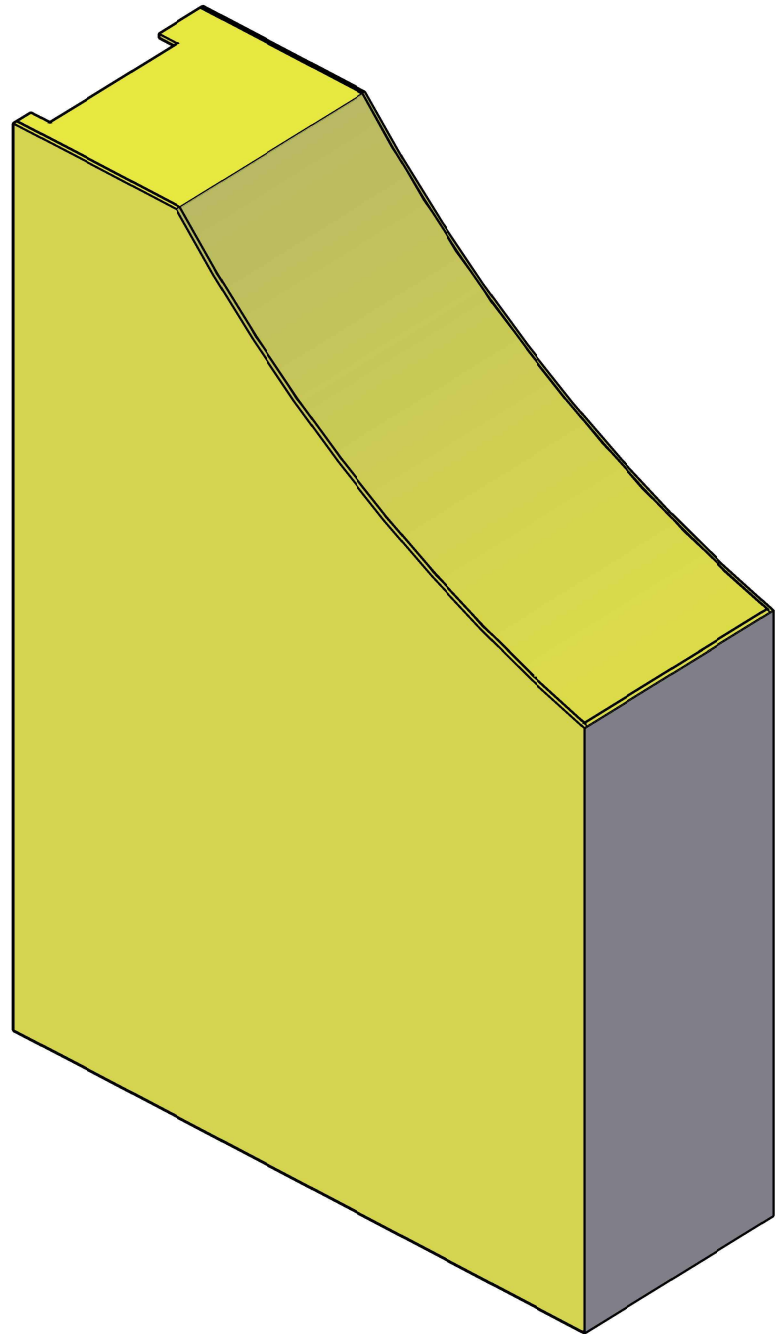

All Dimensions are in m.m.

<b>Creative Museum Designers</b>			
UNIT: Design Section		PROJ: GSI Gwalior Gallery - II	
DRG.NO. CMD-007.12.52.1/EN-4/1	DATE 01/08/2023	SCALE NTS	TOLERANCE
TITLE Ex-1.5, Ex- 4.2			NO OFF 01 OFF 02
Drawn By Mr. Pratik Saha	Checked By Mr. Susanta Shaw	Approved By Mr. K. S. Murali	

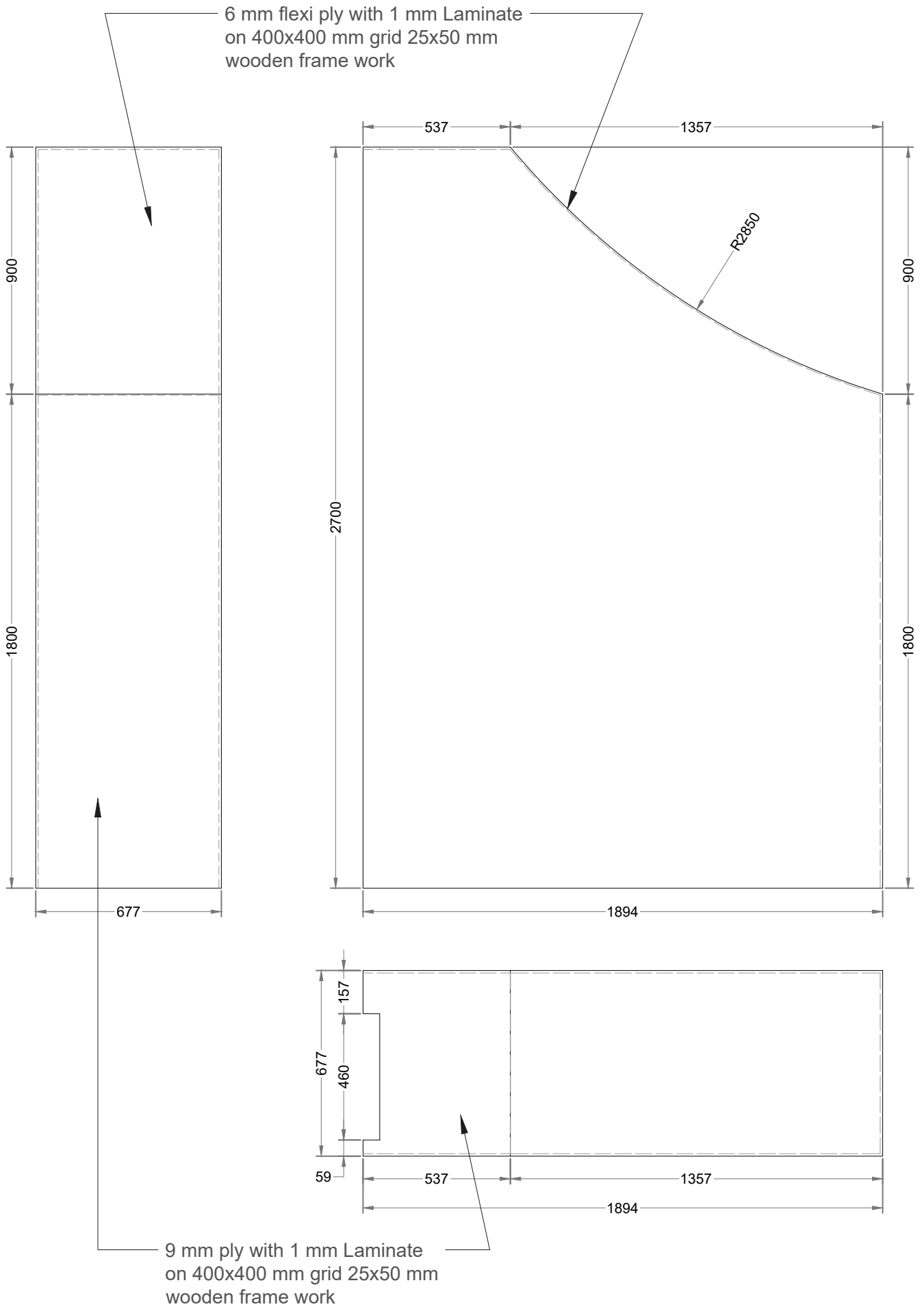

All Dimensions are in m.m.

<b>Creative Museum Designers</b> 			
UNIT: Design Section	PROJ: GSI Gwalior Gallery - II		
DRG.NO. CMD-007.12.52.1/EN-4/1	DATE 01/08/2023	SCALE NTS	TOLERANCE
TITLE Ex-1.5, Ex- 4.2			NO OFF 02 OFF 02
Drawn By Mr. Pratik Saha	Checked By Mr. Susanta Shaw	Approved By Mr. K. S. Murali	

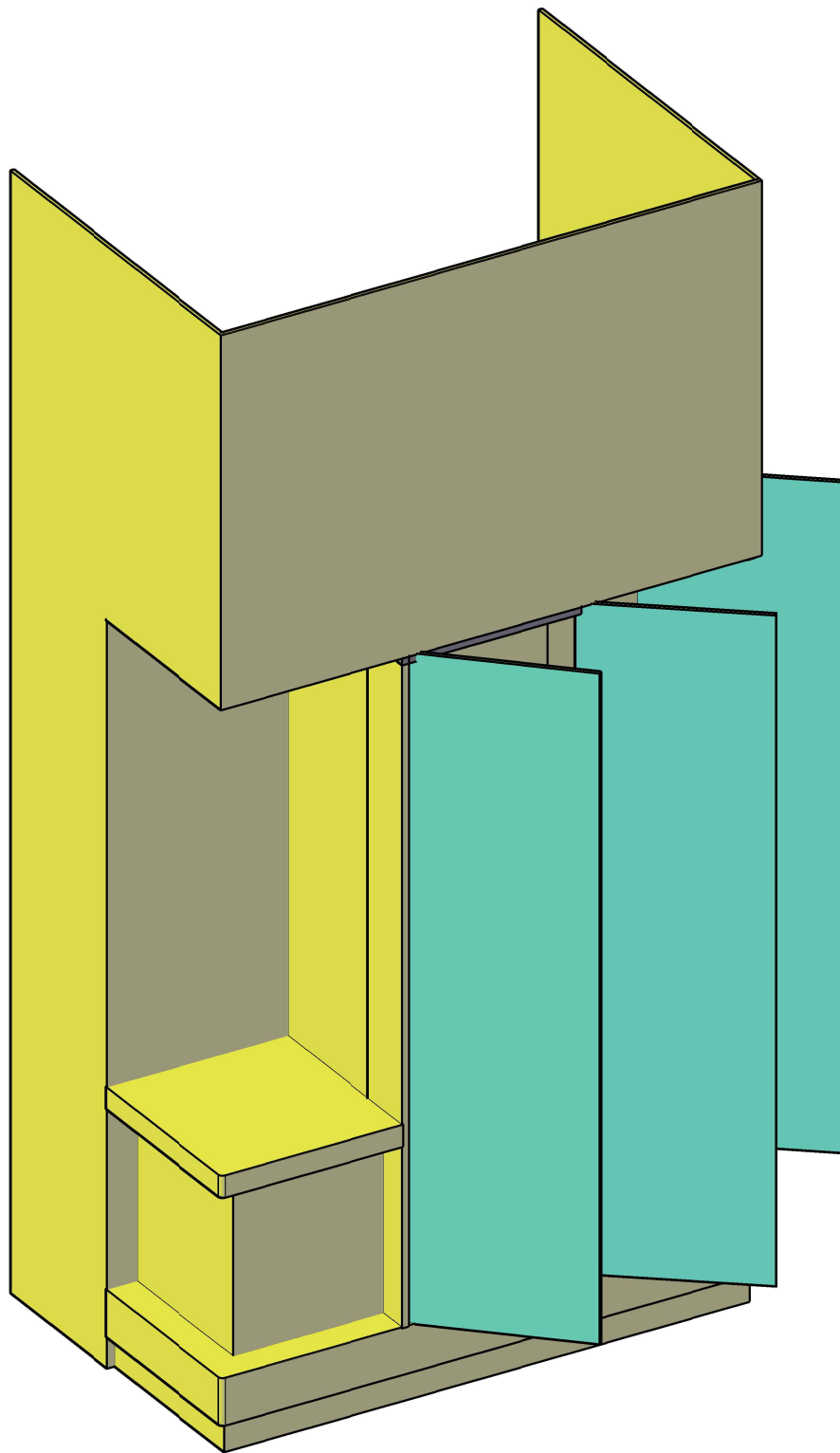

All Dimensions are in m.m.

<b>Creative Museum Designers</b>			
UNIT: Design Section		PROJ: GSI Gwalior Gallery - II	
DRG.NO. CMD-007.12.52.1/EN-4/2	DATE 01/08/2023	SCALE NTS	TOLERANCE
TITLE EX- 4.4			NO OFF 01 OFF 03
Drawn By Mr. Pratik Saha	Checked By Mr. Susanta Shaw	Approved By Mr. K. S. Murali	

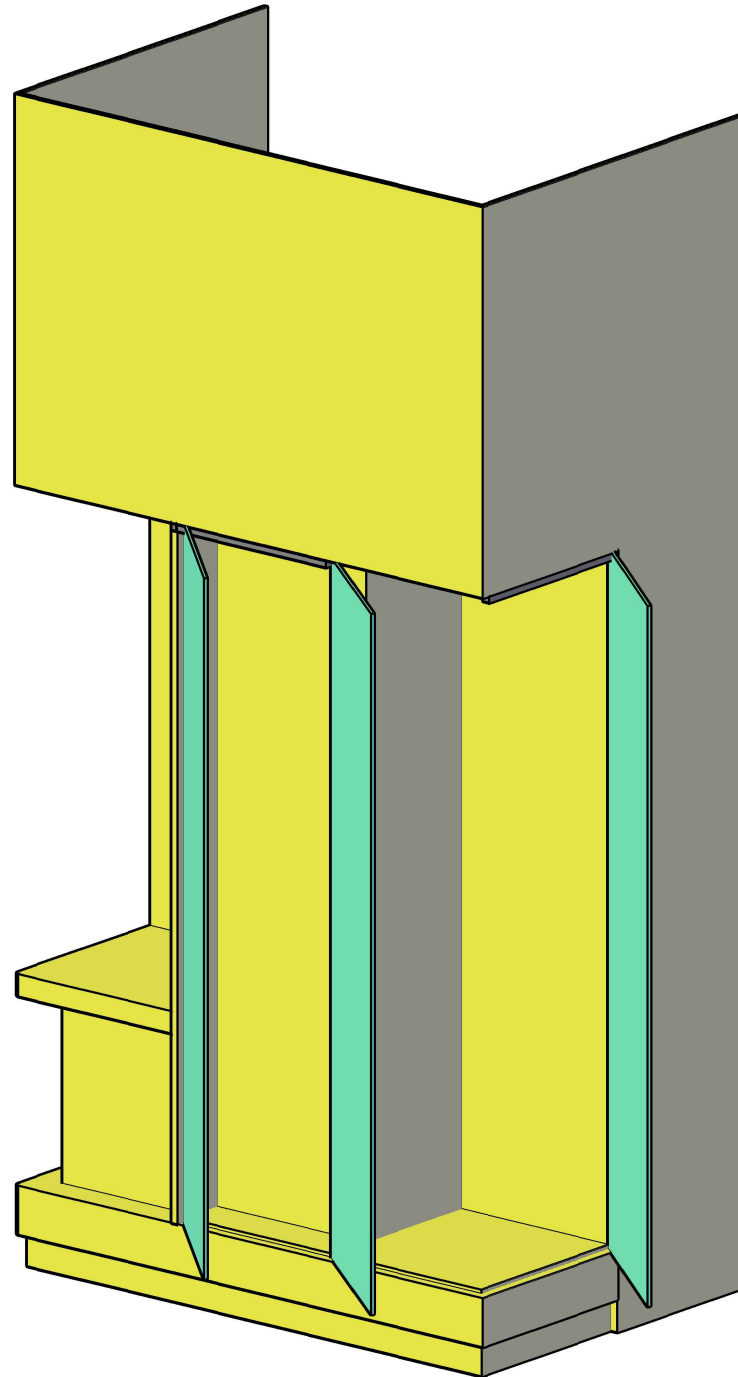

All Dimensions are in m.m.

<b>Creative Museum Designers</b>			
UNIT: Design Section		PROJ: GSI Gwalior Gallery - II	
DRG.NO. CMD-007.12.52.1/EN-4/2	DATE 01/08/2023	SCALE NTS	TOLERANCE
TITLE EX- 4.4			NO OFF 02 OFF 03
Drawn By Mr. Pratik Saha	Checked By Mr. Susanta Shaw	Approved By Mr. K. S. Murali	

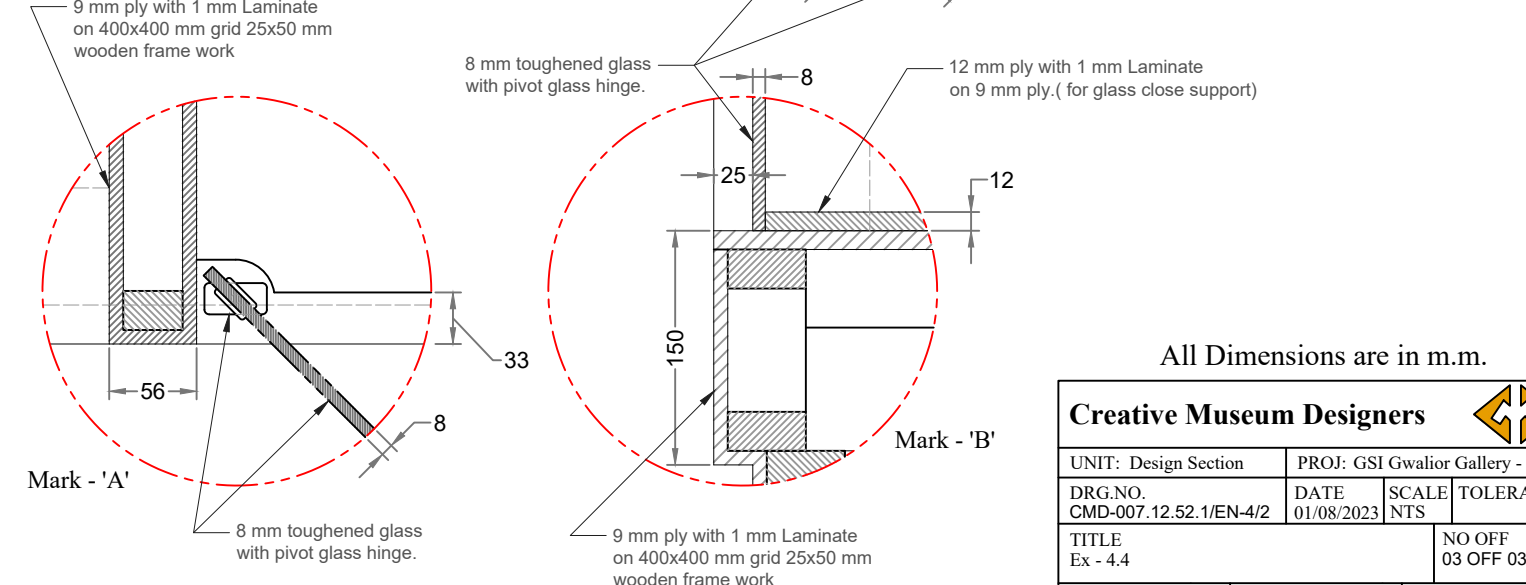
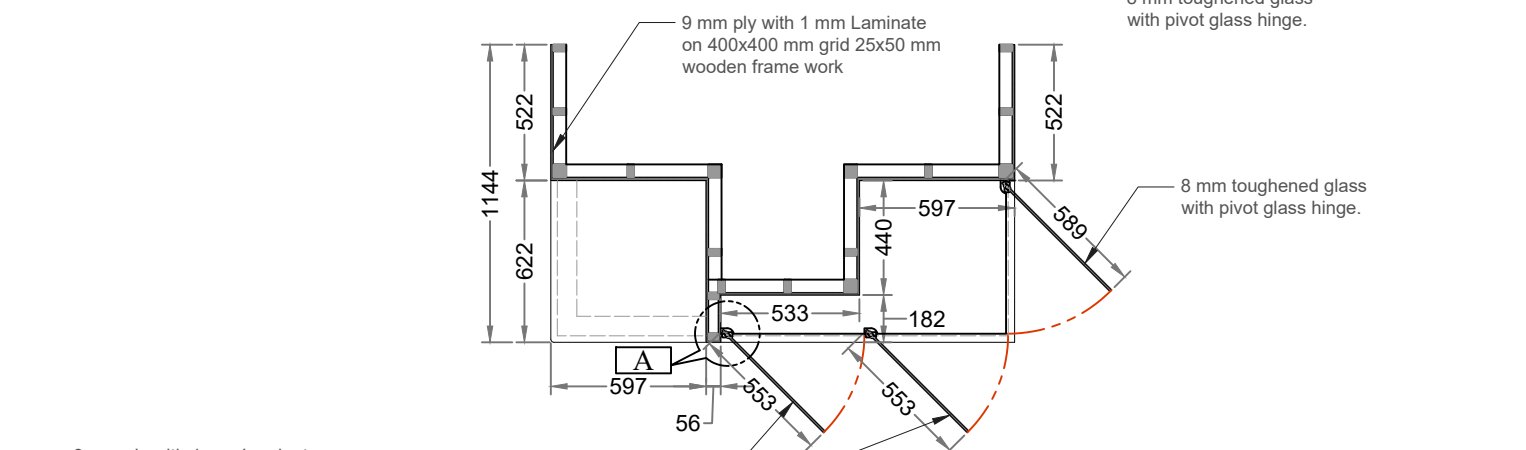
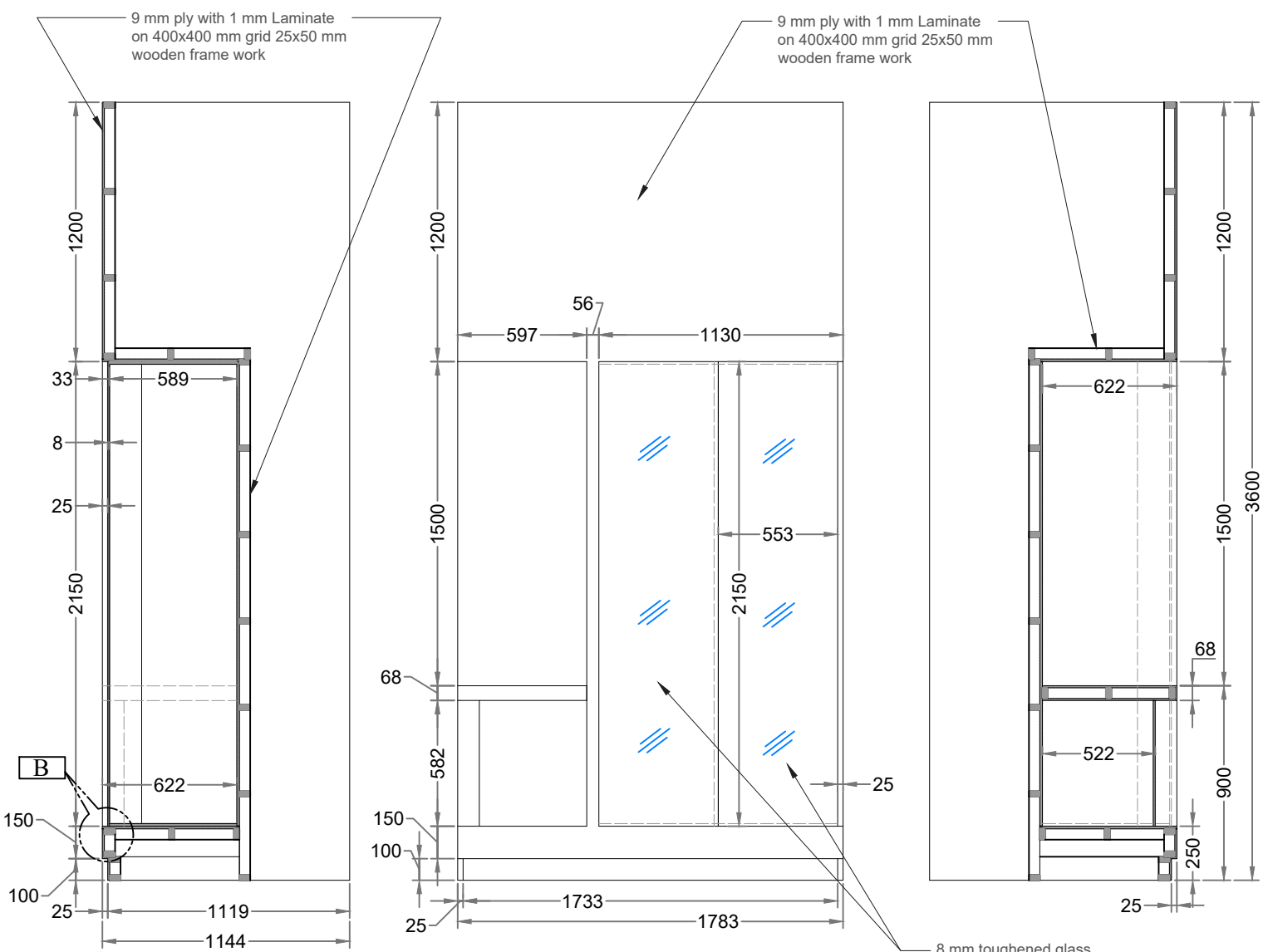

All Dimensions are in m.m.

<b>Creative Museum Designers</b>			
UNIT: Design Section	PROJ: GSI Gwalior Gallery - II		
DRG.NO. CMD-007.12.52.1/EN-4/2	DATE 01/08/2023	SCALE NTS	TOLERANCE
TITLE Ex - 4.4		NO OFF 03 OFF 03	
Drawn By Mr. Pratik Saha	Checked By Mr. Susanta Shaw	Approved By Mr. K. S. Murali	

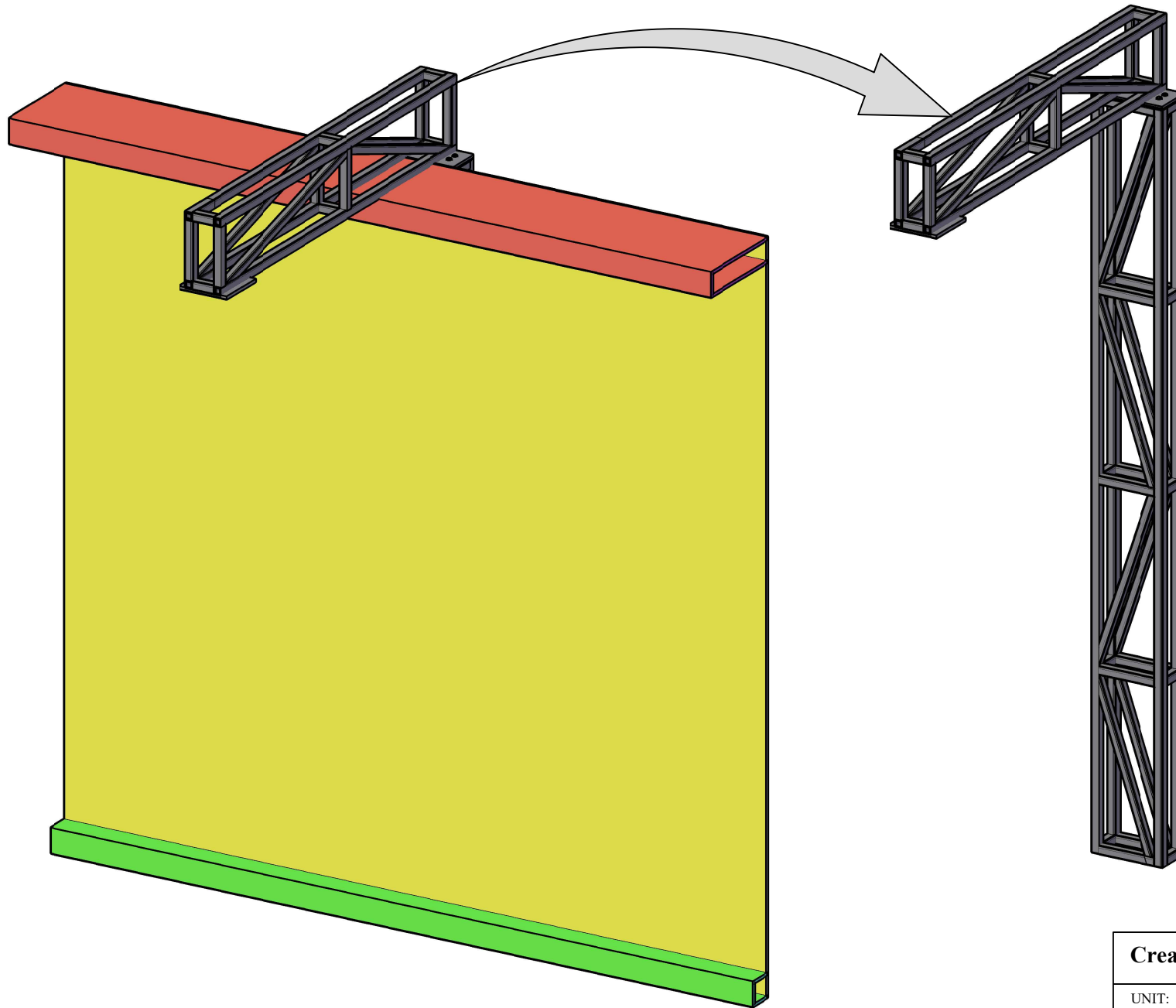

All Dimensions are in m.m.

<b>Creative Museum Designers</b>			
UNIT: Design Section		PROJ: GSI Gwalior Gallery - II	
DRG.NO. CMD-007.12.52.1/EN-5/1	DATE 01/08/2023	SCALE NTS	TOLERANCE
TITLE EX- 5.2			NO OFF 01 OFF 02
Drawn By Mr. Pratik Saha	Checked By Mr. Susanta Shaw	Approved By Mr. K. S. Murali	



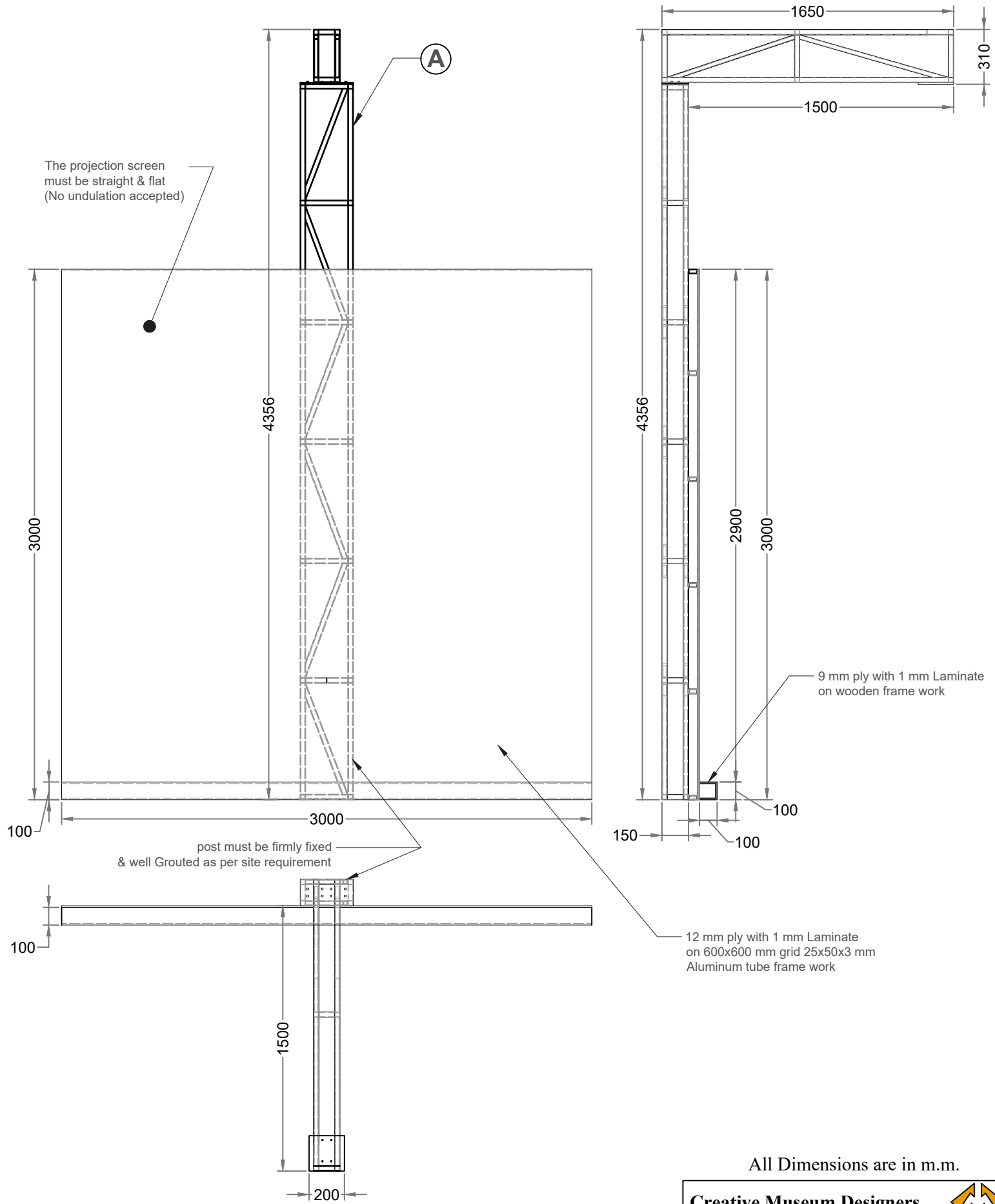

All Dimensions are in m.m.

<b>Creative Museum Designers</b>				
UNIT: Design Section		PROJ: GSI Gwalior Gallery - II		
DRG.NO. CMD-007.12.52.1/EN-5/1	DATE 01/08/2023	SCALE NTS	TOLERANCE	
TITLE Ex - 5.2			NO OFF 02 OFF 03	
Drawn By Mr. Pratik Saha	Checked By Mr. Susanta Shaw	Approved By Mr. K. S. Murali		

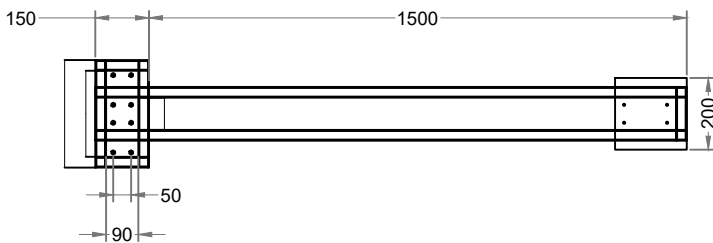
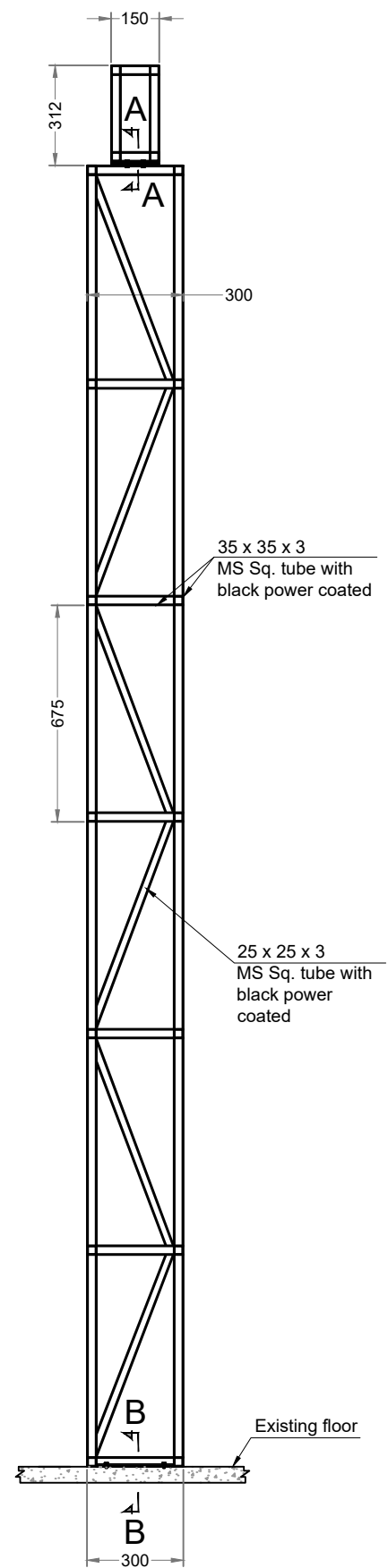
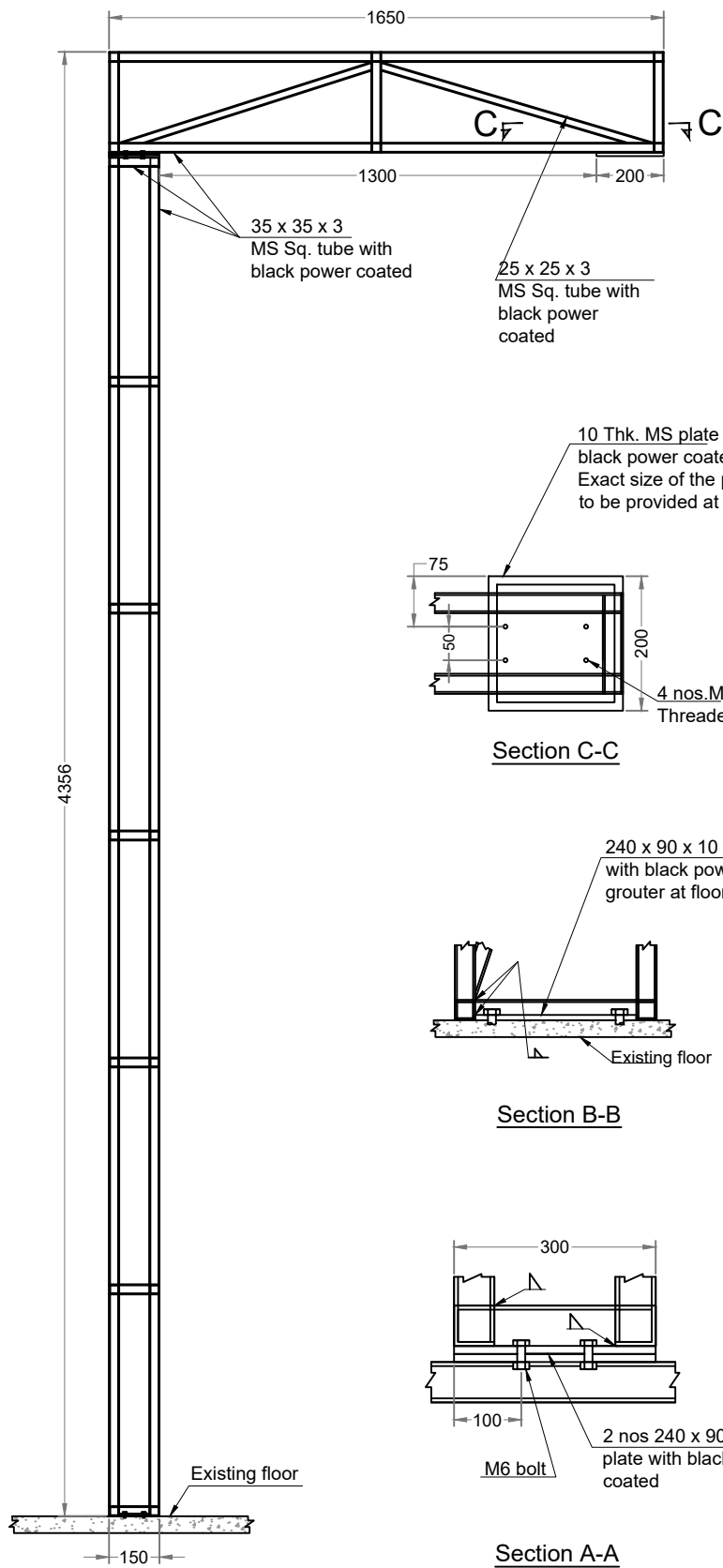

All Dimensions are in m.m.

<b>Creative Museum Designers</b>				
UNIT: Design Section		PROJ: GSI Gwalior Gallery - II		
DRG.NO. CMD-007.12.52.1/EN-5/1	DATE 01/08/2023	SCALE NTS	TOLERANCE	
TITLE Ex - 5.2			NO OFF 03 OFF 03	
Drawn By Mr. Pratik Saha	Checked By Mr. Susanta Shaw	Approved By Mr. K. S. Murali		

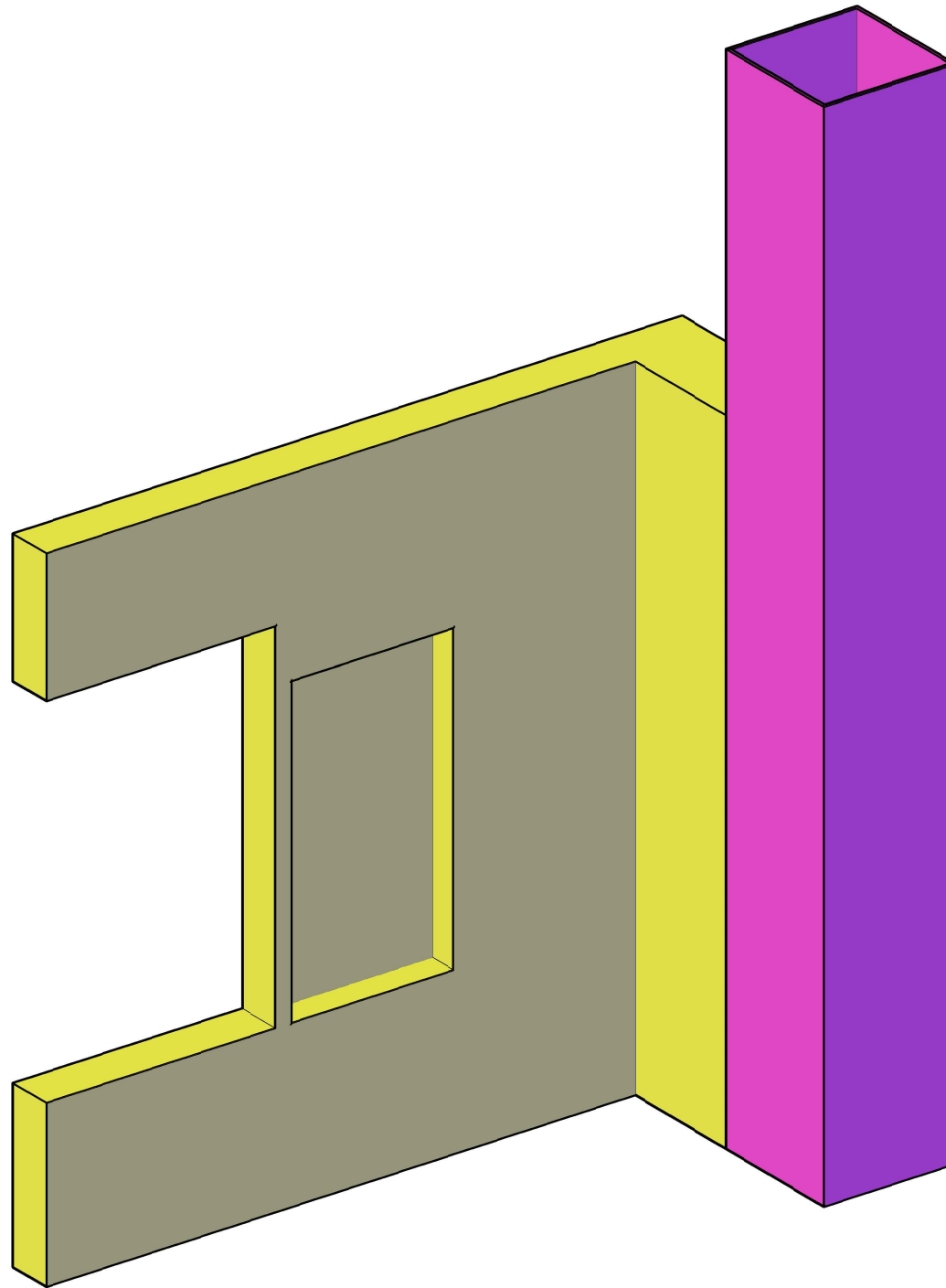

All Dimensions are in m.m.

<b>Creative Museum Designers</b>			
UNIT: Design Section		PROJ: GSI Gwalior Gallery - II	
DRG.NO. CMD-007.12.52.1/EN-5/2	DATE 01/08/2023	SCALE NTS	TOLERANCE
TITLE Ex - 5.4 , Ex- 6.1			NO OFF 01 OFF 03
Drawn By Mr. Pratik Saha	Checked By Mr. Susanta Shaw	Approved By Mr. K. S. Murali	

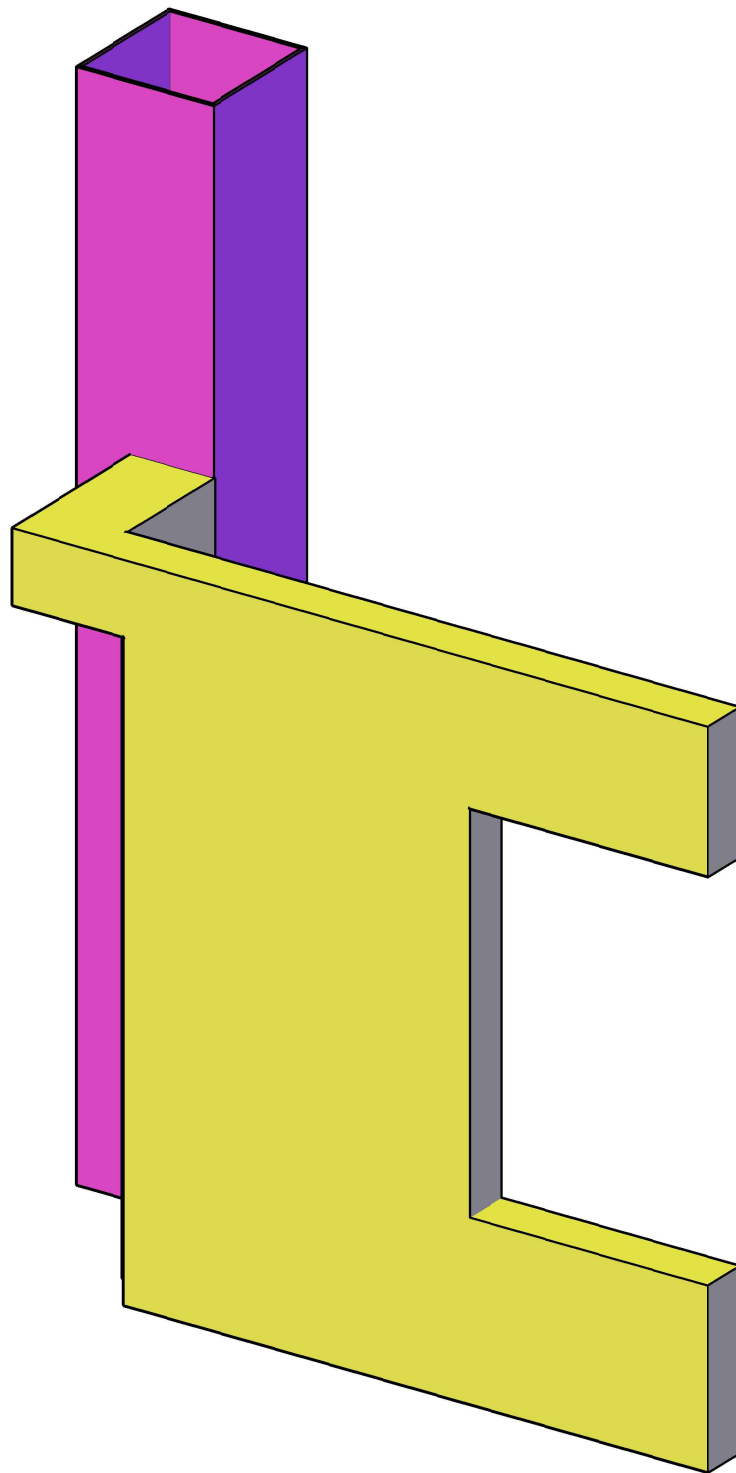

All Dimensions are in m.m.

<b>Creative Museum Designers</b>			
UNIT: Design Section		PROJ: GSI Gwalior Gallery - II	
DRG.NO. CMD-007.12.52.1/EN-5/2	DATE 01/08/2023	SCALE NTS	TOLERANCE
TITLE EX- 5.4, Ex - 6.1			NO OFF 02 OFF 03
Drawn By Mr. Pratik Saha	Checked By Mr. Susanta Shaw	Approved By Mr. K. S. Murali	

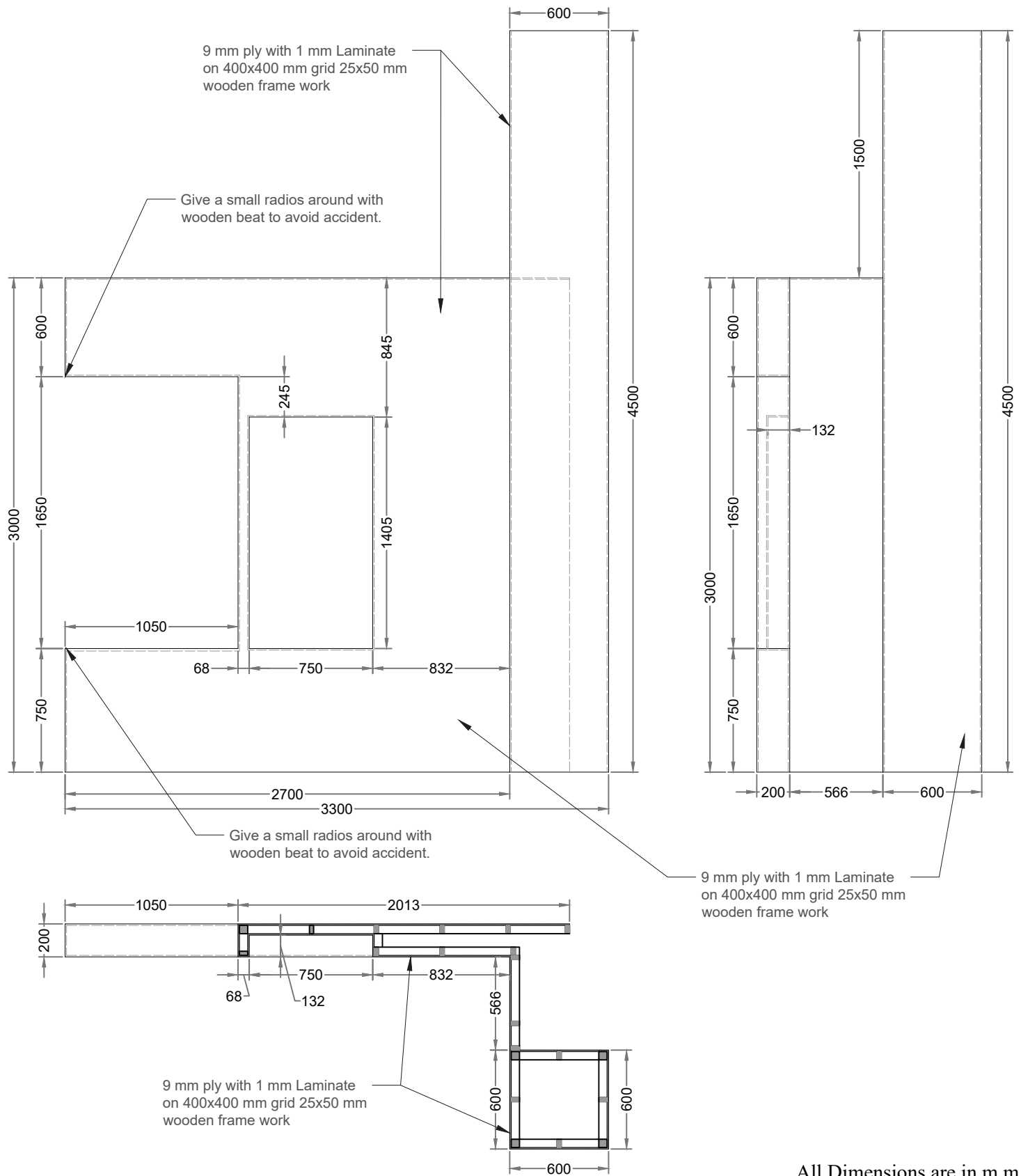

All Dimensions are in m.m.

<b>Creative Museum Designers</b> 			
UNIT: Design Section		PROJ: GSI Gwalior Gallery - II	
DRG.NO. CMD-007.12.52.1/EN-5/2	DATE 01/08/2023	SCALE NTS	TOLERANCE NO OFF 03 OFF 03
TITLE Ex - 5.4 , Ex- 6.1			NO OFF 03 OFF 03
Drawn By Mr. Pratik Saha	Checked By Mr. Susanta Shaw	Approved By Mr. K. S. Murali	

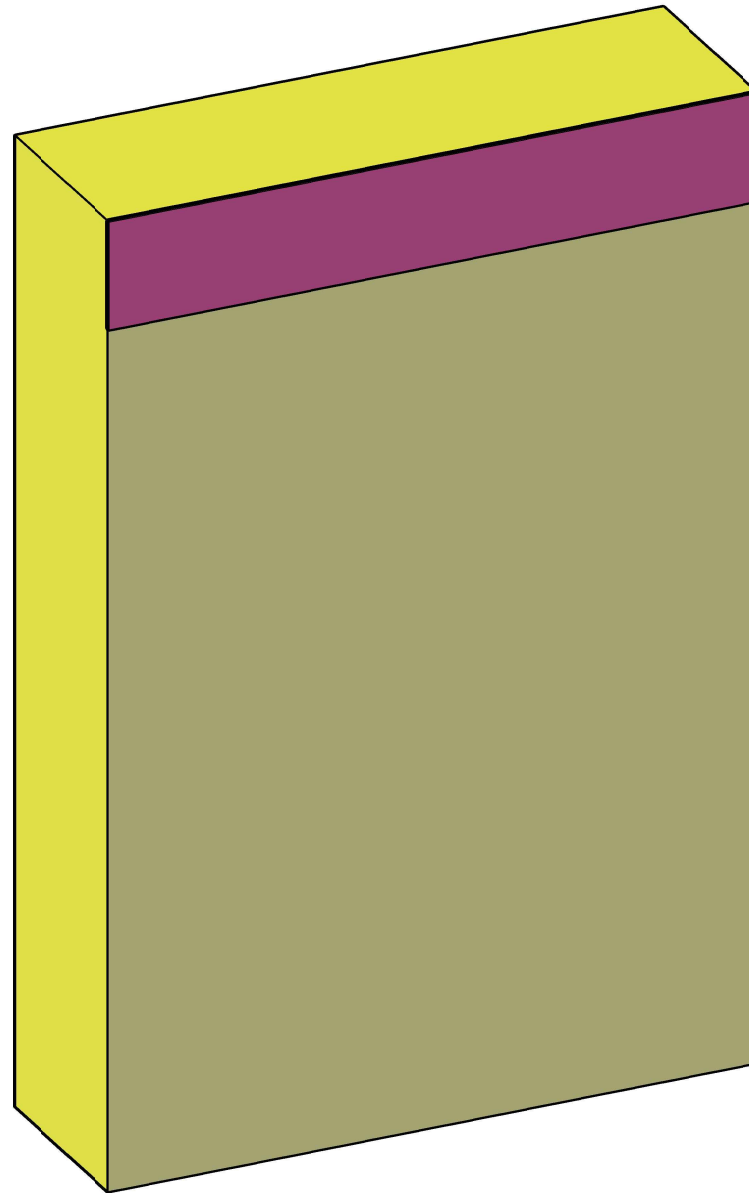

All Dimensions are in m.m.

<b>Creative Museum Designers</b>			
UNIT: Design Section		PROJ: GSI Gwalior Gallery - II	
DRG.NO. CMD-007.12.52.1/EN-6/1	DATE 01/08/2023	SCALE NTS	TOLERANCE
TITLE Ex - 6.2			NO OFF 01 OFF 02
Drawn By Mr. Pratik Saha	Checked By Mr. Susanta Shaw	Approved By Mr. K. S. Murali	

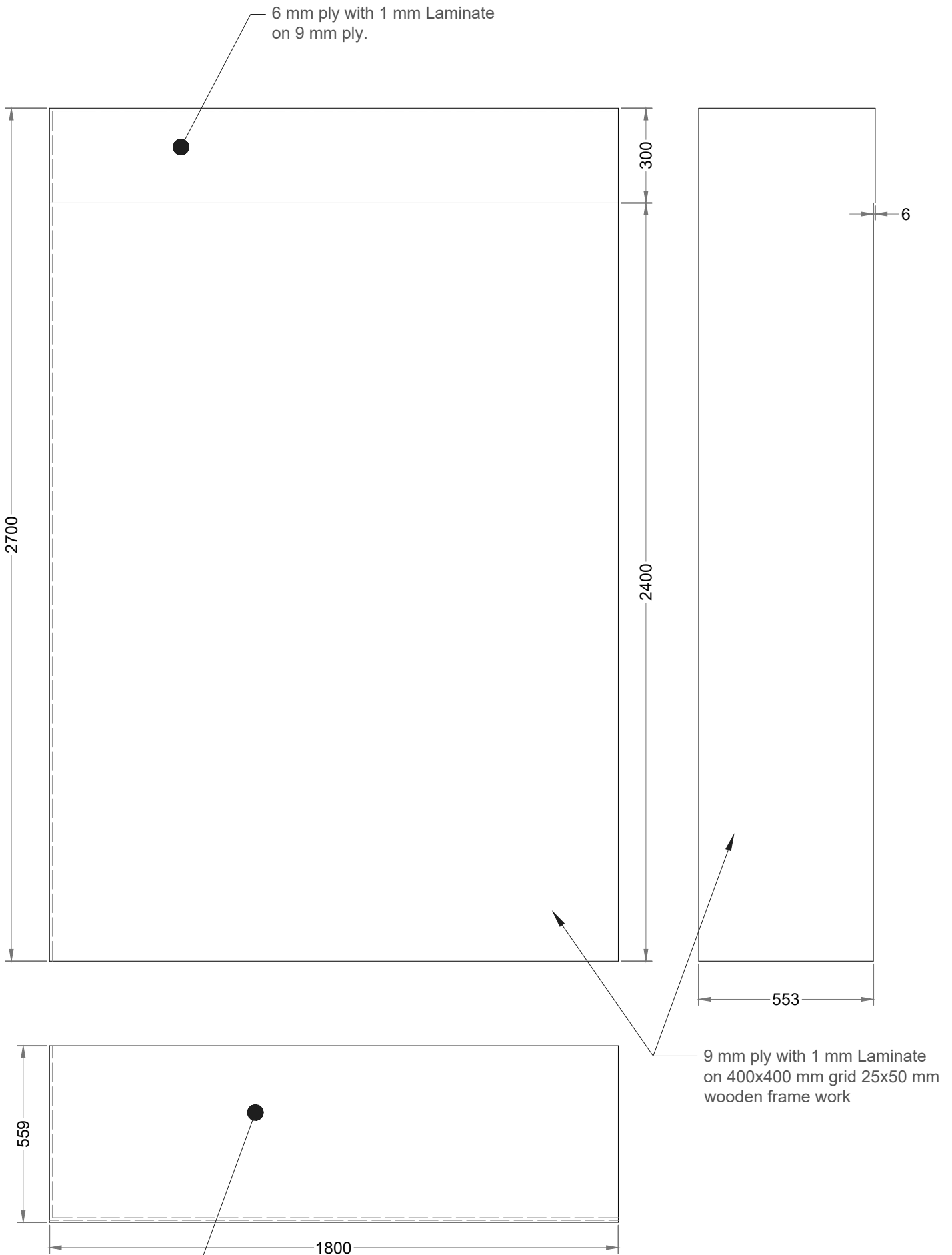

All Dimensions are in m.m.

<b>Creative Museum Designers</b>			
UNIT: Design Section	PROJ: GSI Gwalior Gallery - II		
DRG.NO. CMD-007.12.52.1/EN-6/1	DATE 01/08/2023	SCALE NTS	TOLERANCE
TITLE Ex - 6.2			NO OFF 02 OFF 02
Drawn By Mr. Pratik Saha	Checked By Mr. Susanta Shaw	Approved By Mr. K. S. Murali	

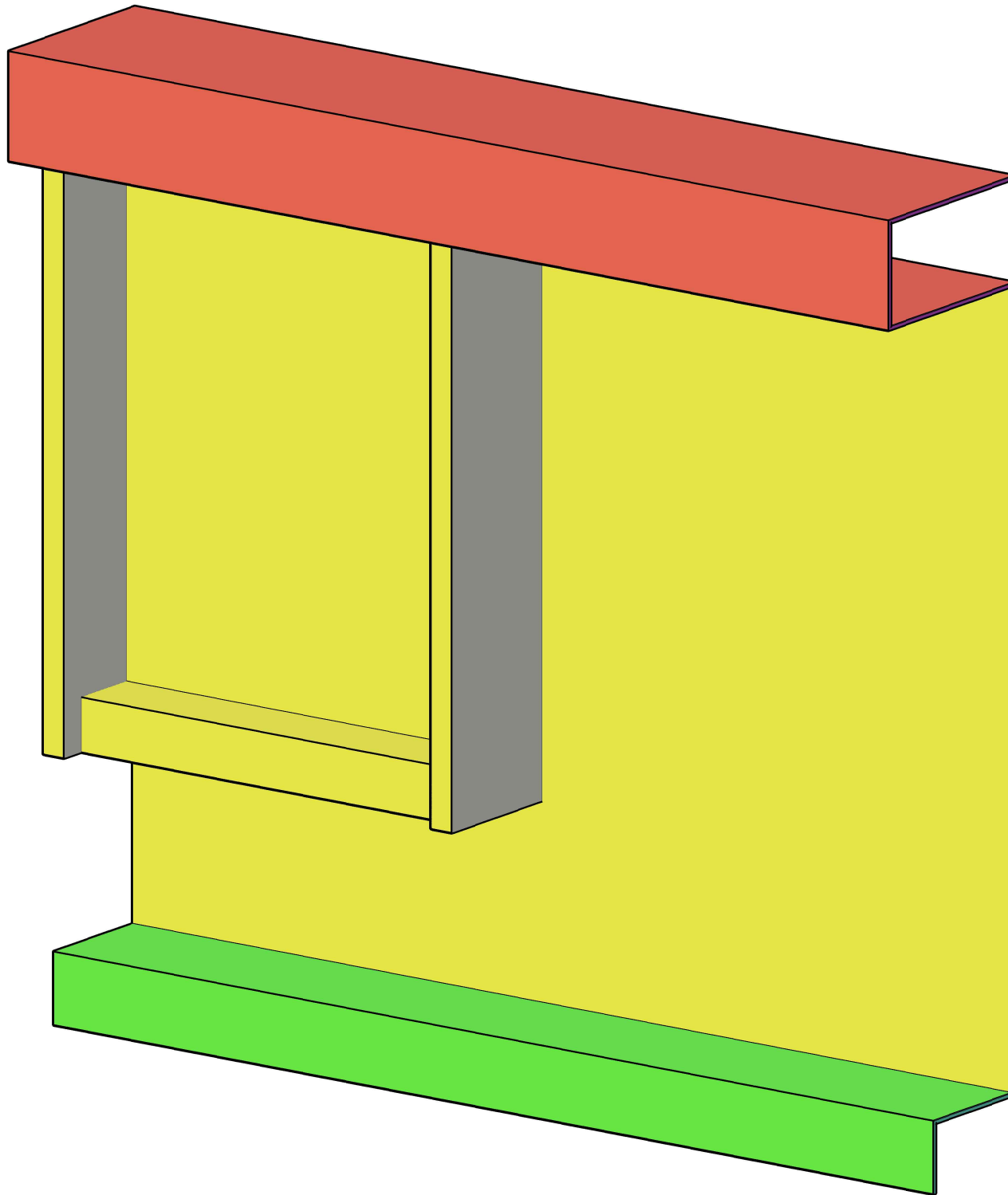

All Dimensions are in m.m.

<b>Creative Museum Designers</b>			
UNIT: Design Section		PROJ: GSI Gwalior Gallery - II	
DRG.NO. CMD-007.12.52.1/EN-6/2	DATE 01/08/2023	SCALE NTS	TOLERANCE
TITLE EX- 6.3, Ex - 6.4			NO OFF 01 OFF 02
Drawn By Mr. Pratik Saha	Checked By Mr. Susanta Shaw	Approved By Mr. K. S. Murali	



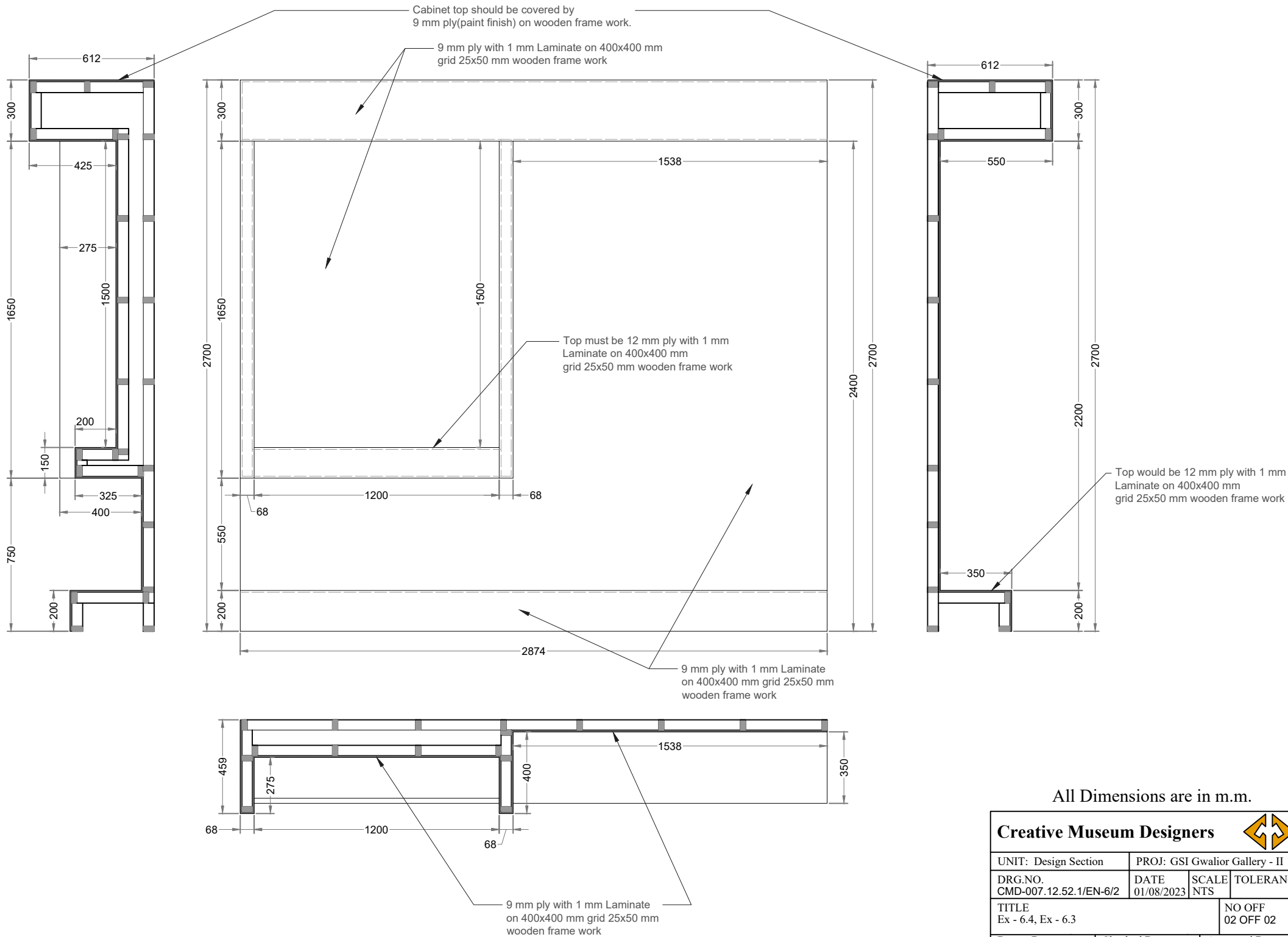

All Dimensions are in m.m.

<b>Creative Museum Designers</b>				
UNIT: Design Section		PROJ: GSI Gwalior Gallery - II		
DRG.NO. CMD-007.12.52.1/EN-6/2	DATE 01/08/2023	SCALE NTS	TOLERANCE	
TITLE Ex - 6.4, Ex - 6.3			NO OFF 02 OFF 02	
Drawn By Mr. Pratik Saha	Checked By Mr. Susanta Shaw	Approved By Mr. K. S. Murali		

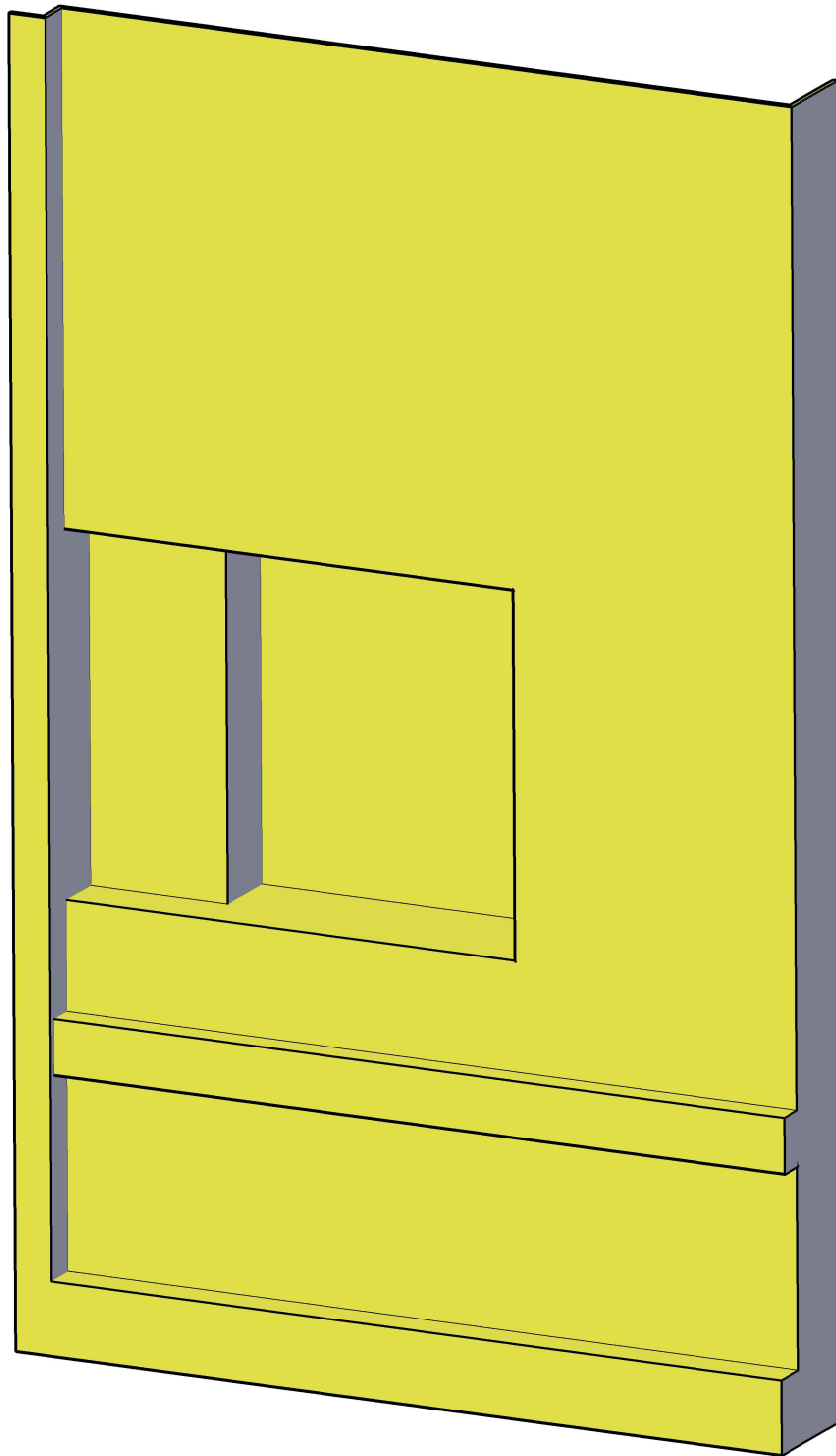

All Dimensions are in m.m.

<b>Creative Museum Designers</b>			
UNIT: Design Section		PROJ: GSI Gwalior Gallery - II	
DRG.NO. CMD-007.12.52.1/EN-6/3	DATE 01/08/2023	SCALE NTS	TOLERANCE
TITLE EX- 6.5			NO OFF 01 OFF 02
Drawn By Mr. Pratik Saha	Checked By Mr. Susanta Shaw	Approved By Mr. K. S. Murali	

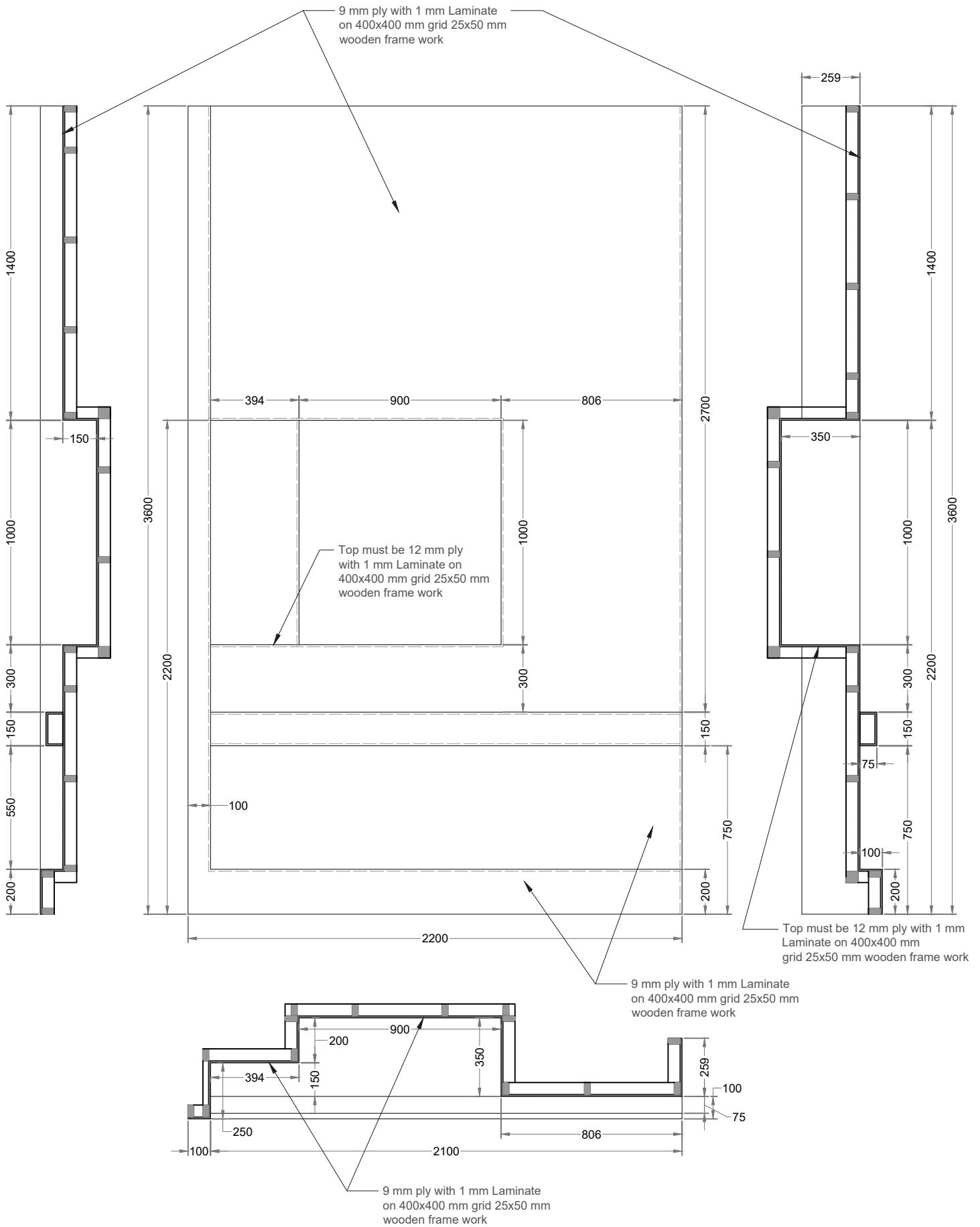

All Dimensions are in m.m.

<b>Creative Museum Designers</b>				
UNIT: Design Section		PROJ: GSI Gwalior Gallery - II		
DRG.NO. CMD-007.12.52.1/EN-6/3	DATE 01/08/2023	SCALE NTS	TOLERANCE	
TITLE Ex - 6.5			NO OFF 02 OFF 02	
Drawn By Mr. Pratik Saha	Checked By Mr. Susanta Shaw	Approved By Mr. K. S. Murali		

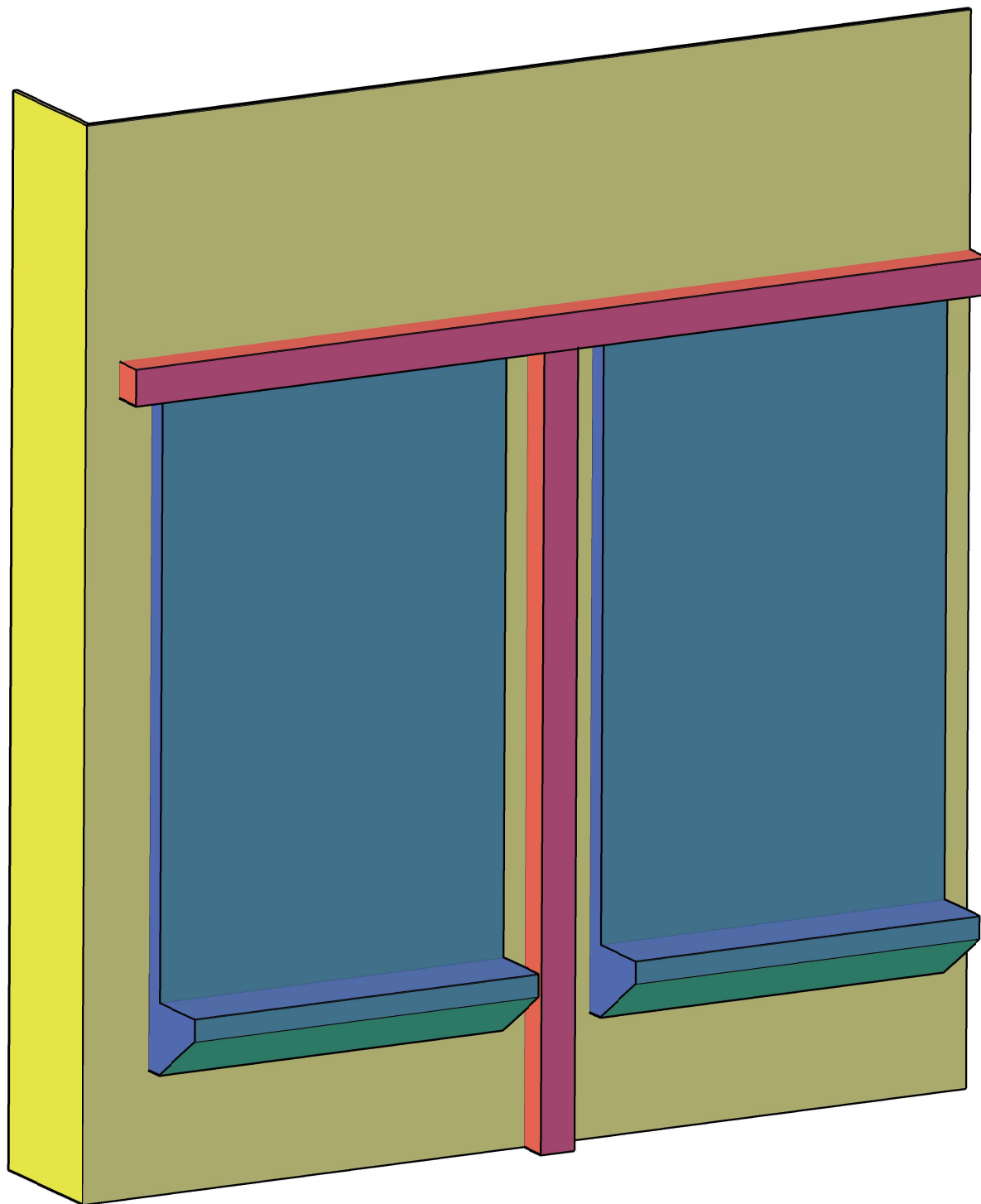

All Dimensions are in m.m.

<b>Creative Museum Designers</b>			
UNIT: Design Section		PROJ: GSI Gwalior Gallery - II	
DRG.NO. CMD-007.12.52.1/EN-6/4	DATE 01/08/2023	SCALE NTS	TOLERANCE
TITLE Ex- 6.6, Ex- 6.7			NO OFF 01 OFF 02
Drawn By Mr. Pratik Saha	Checked By Mr. Susanta Shaw	Approved By Mr. K. S. Murali	

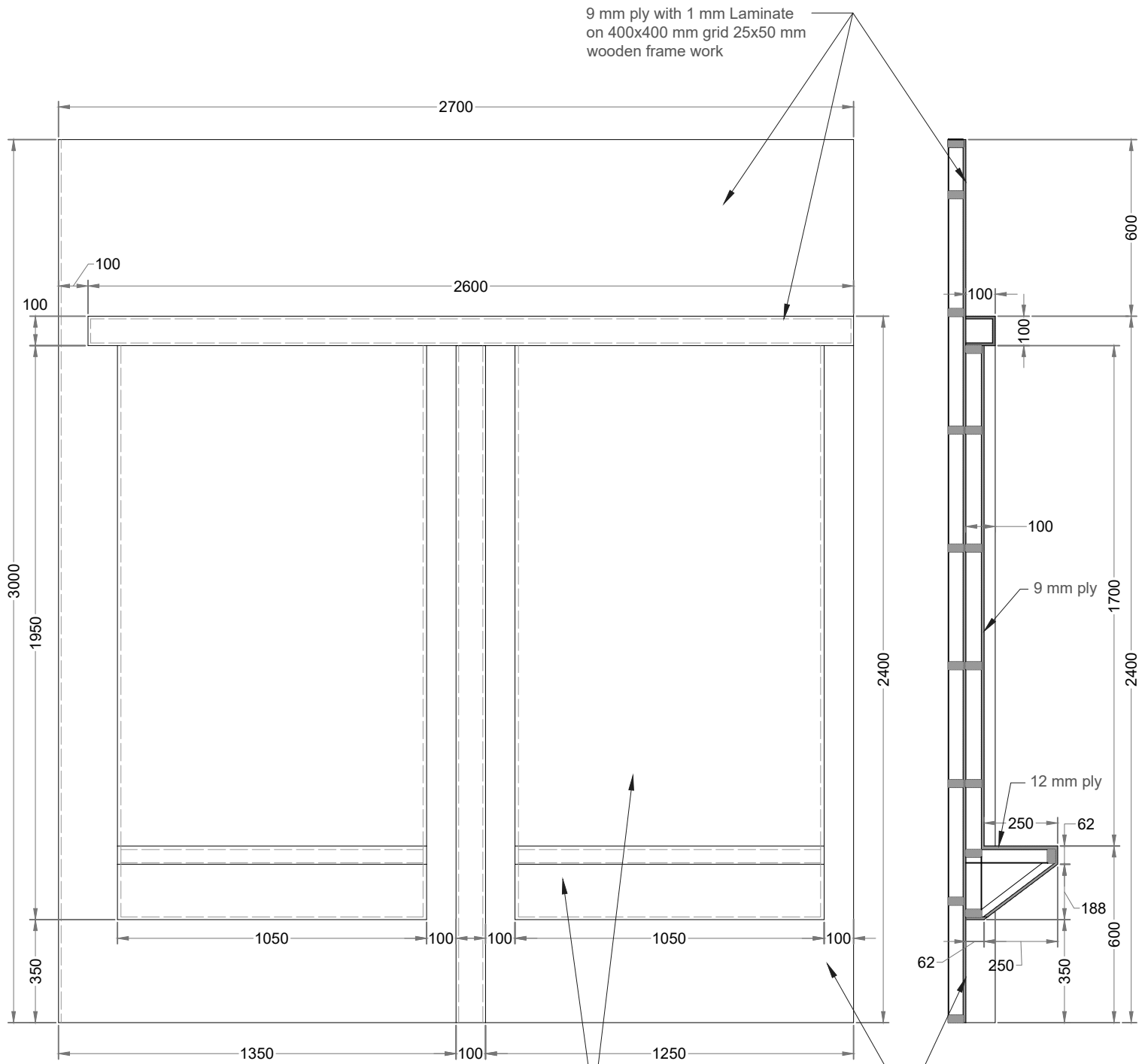

9 mm ply with 1 mm Laminate  
on 400x400 mm grid 25x50 mm  
wooden frame work

9 mm ply with 1 mm Laminate  
on 400x400 mm grid 25x50 mm  
wooden frame work

Top would be 12 mm ply  
with 1 mm Laminate on  
400x400 mm grid 25x50 mm  
wooden frame work

All Dimensions are in m.m.

<b>Creative Museum Designers</b>				
UNIT: Design Section		PROJ: GSI Gwalior Gallery - II		
DRG.NO. CMD-007.12.52.1/EN-6/4	DATE 01/08/2023	SCALE NTS	TOLERANCE	
TITLE Ex - 6.6, Ex - 6.7			NO OFF 02 OFF 02	
Drawn By Mr. Pratik Saha	Checked By Mr. Susanta Shaw	Approved By Mr. K. S. Murali		

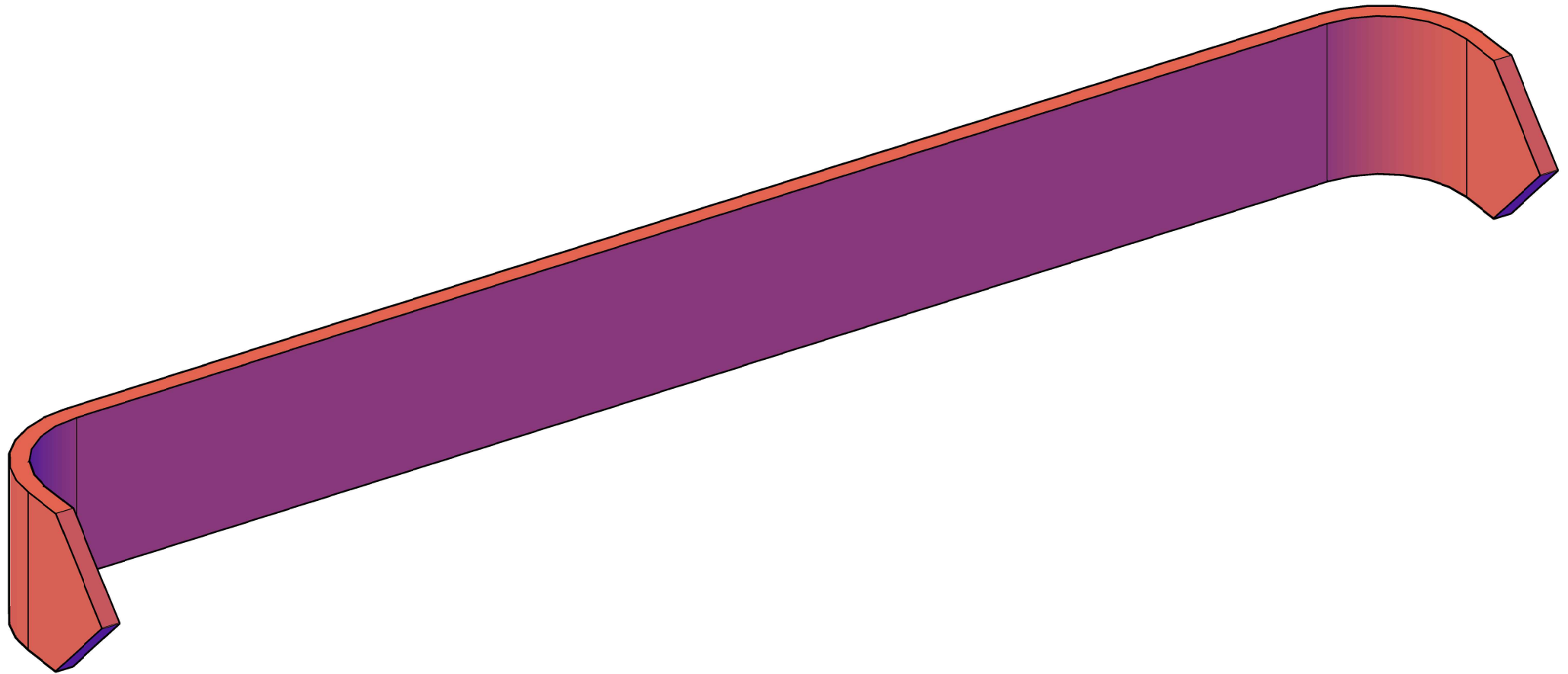

All Dimensions are in m.m.

<b>Creative Museum Designers</b>			
UNIT: Design Section		PROJ: GSI Gwalior Gallery - II	
DRG.NO. CMD-007.12.52.1/EN-6/5	DATE 01/08/2023	SCALE NTS	TOLERANCE
TITLE Ex - 6.6 and 6.7, 6.8 connected Band			NO OFF 01 OFF 02
Drawn By Mr. Pratik Saha	Checked By Mr. Susanta Shaw	Approved By Mr. K. S. Murali	

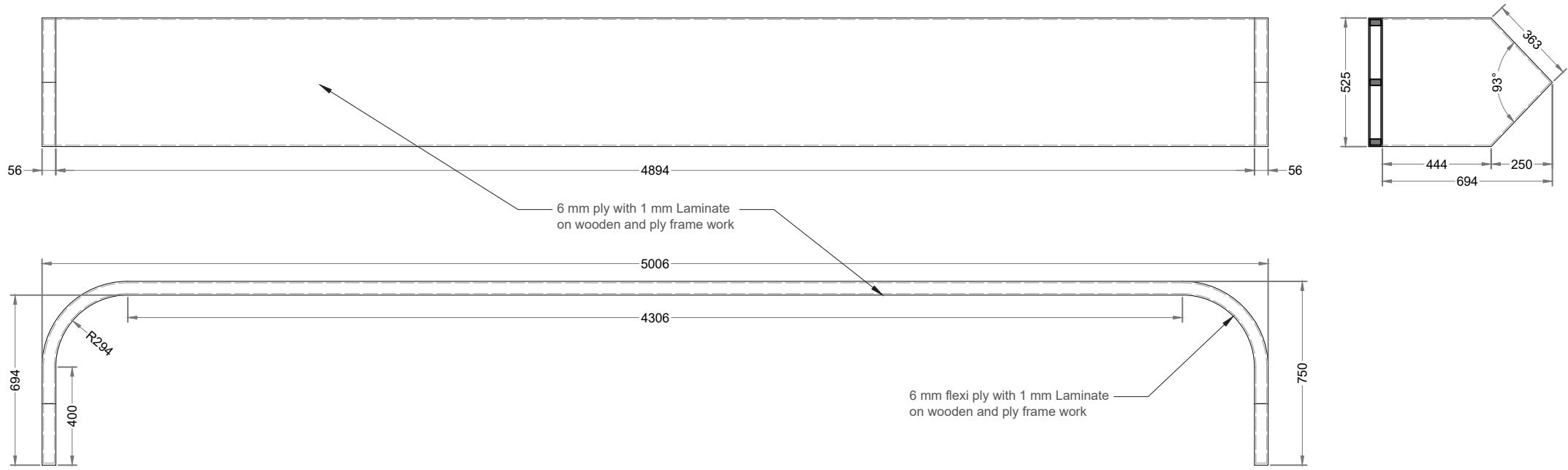

All Dimensions are in m.m.

<b>Creative Museum Designers</b>				
UNIT: Design Section		PROJ: GSI Gwalior Gallery - II		
DRG.NO. CMD-007.12.52.1/EN-6/5	DATE 01/08/2023	SCALE NTS	TOLERANCE	
TITLE Ex - 6.6 and 6.7, 6.8 connected Band			NO OFF 02 OFF 02	
Drawn By Mr. Pratik Saha	Checked By Mr. Susanta Shaw	Approved By Mr. K. S. Murali		

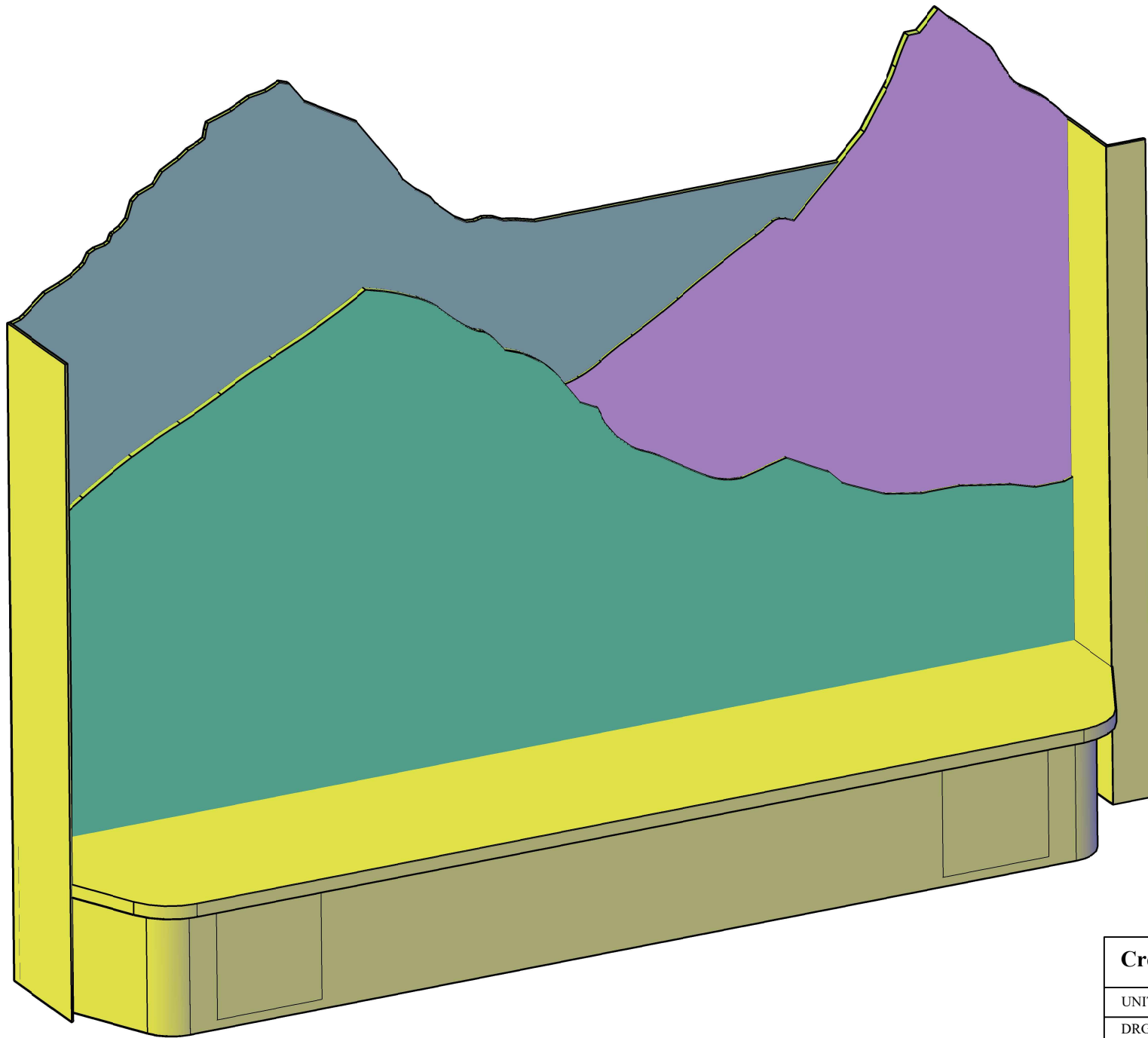

All Dimensions are in m.m.

<b>Creative Museum Designers</b>			
UNIT: Design Section		PROJ: GSI Gwalior Gallery - II	
DRG.NO. CMD-007.12.52.1/EN-6/6	DATE 01/08/2023	SCALE NTS	TOLERANCE
TITLE Ex- 6.8			NO OFF 01 OFF 02
Drawn By Mr. Pratik Saha	Checked By Mr. Susanta Shaw	Approved By Mr. K. S. Murali	



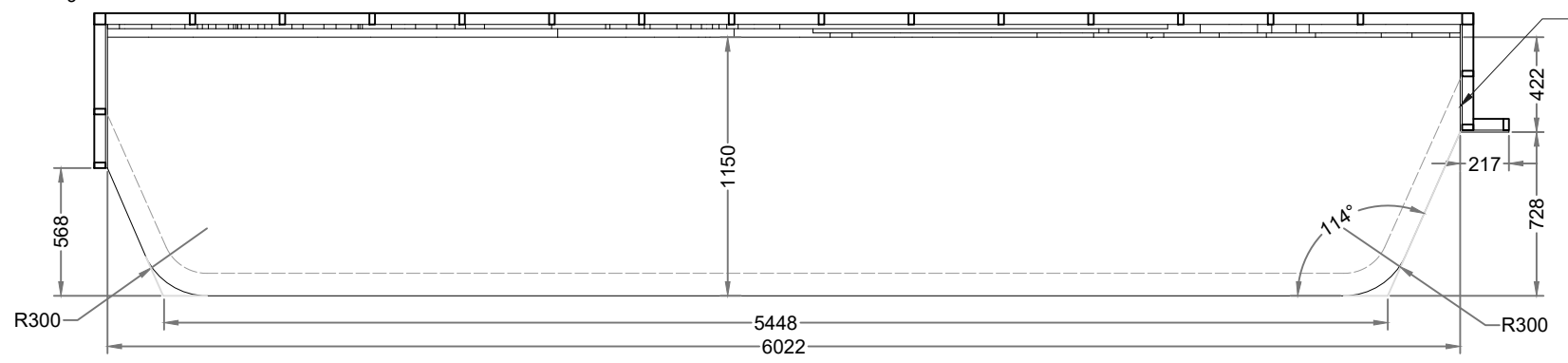
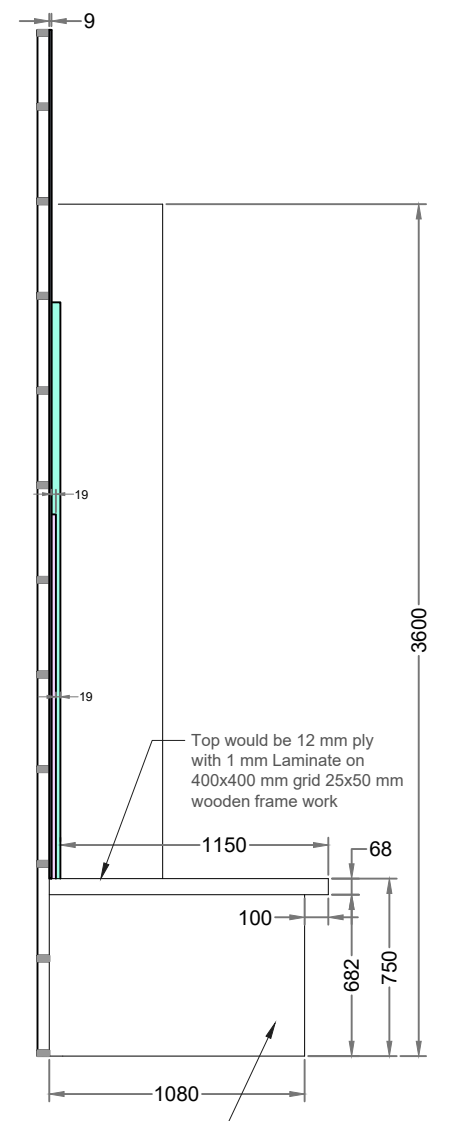
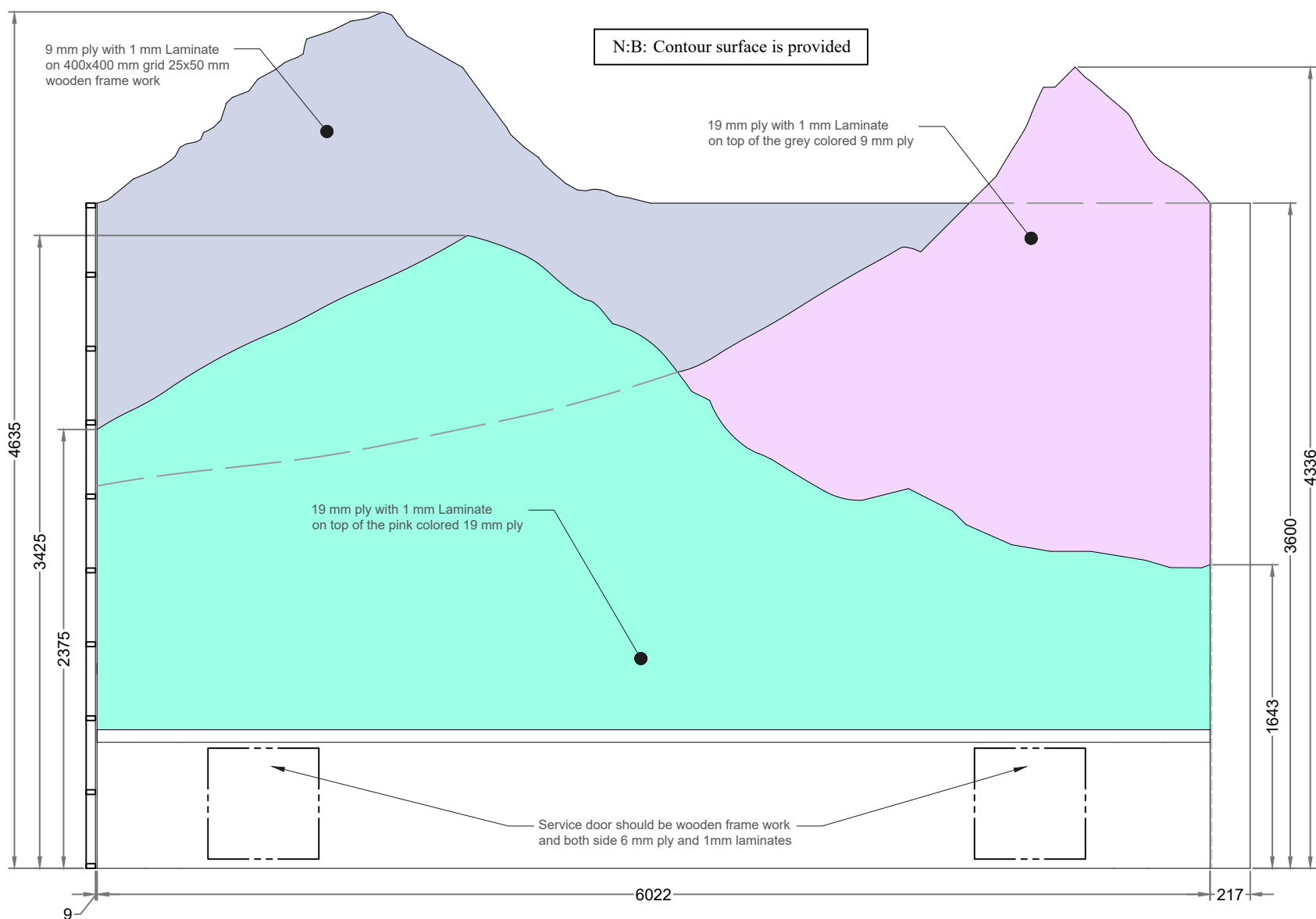

All Dimensions are in m.m.

<b>Creative Museum Designers</b>			
UNIT: Design Section	PROJ: GSI Gwalior Gallery - II		
DRG.NO. CMD-007.12.52.1/EN-6/6	DATE 01/08/2023	SCALE NTS	TOLERANCE
TITLE Ex - 6.8			NO OFF 02 OFF 02
Drawn By Mr. Pratik Saha	Checked By Mr. Susanta Shaw	Approved By Mr. K. S. Murali	

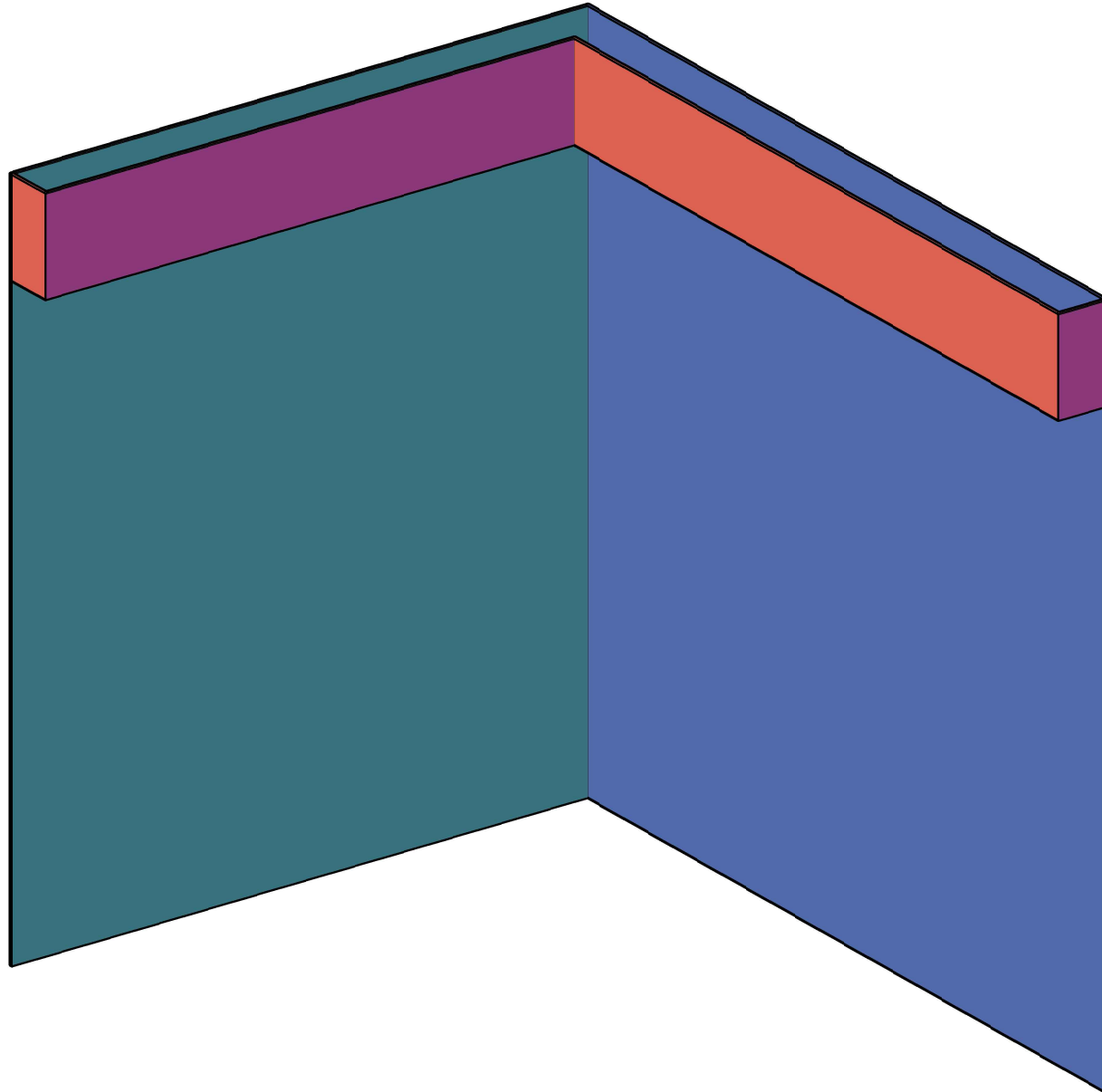

All Dimensions are in m.m.

<b>Creative Museum Designers</b>			
UNIT: Design Section		PROJ: GSI Gwalior Gallery - II	
DRG.NO. CMD-007.12.52.1/EN-7/1	DATE 01/08/2023	SCALE NTS	TOLERANCE
TITLE Ex - 7.1, Ex - 7.2			NO OFF 01 OFF 02
Drawn By Mr. Pratik Saha	Checked By Mr. Susanta Shaw	Approved By Mr. K. S. Murali	

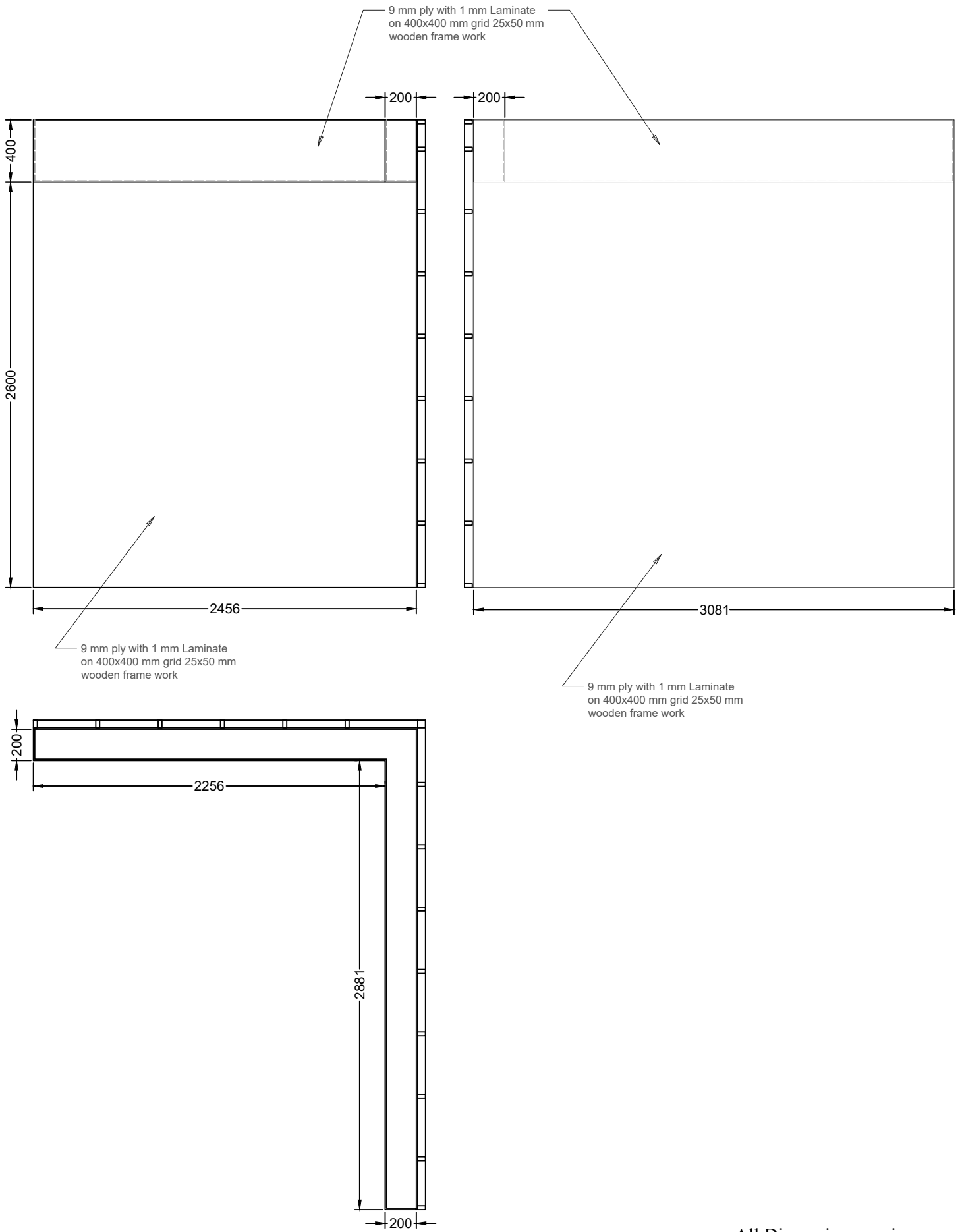

All Dimensions are in m.m.

<b>Creative Museum Designers</b>				
UNIT: Design Section		PROJ: GSI Gwalior Gallery - II		
DRG.NO. CMD-007.12.52.1/EN-7/1	DATE 01/08/2023	SCALE NTS	TOLERANCE	
TITLE Ex - 7.1, Ex - 7.2			NO OFF 02 OFF 02	
Drawn By Mr. Pratik Saha	Checked By Mr. Susanta Shaw	Approved By Mr. K. S. Murali		

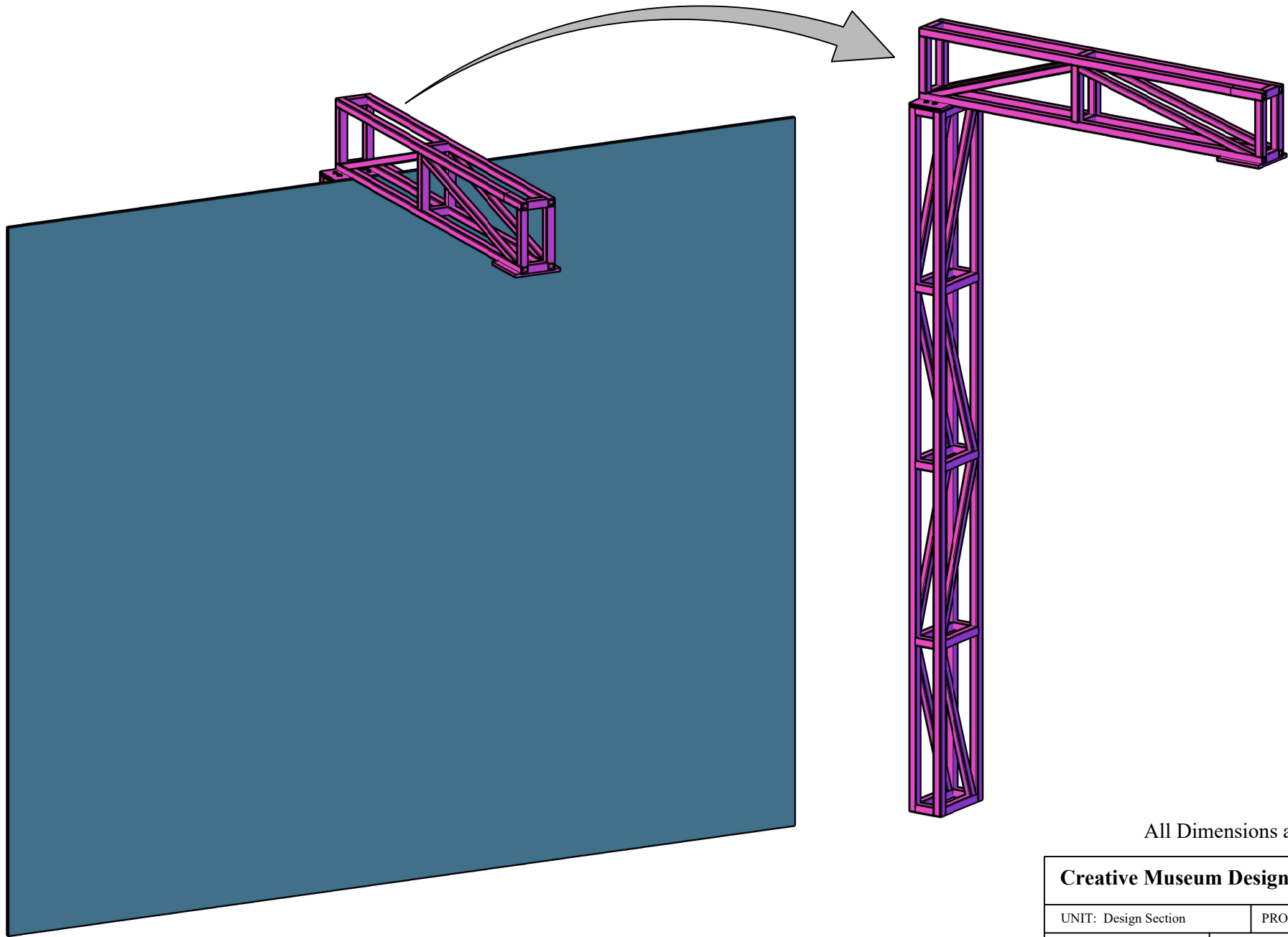

All Dimensions are in m.m.

<b>Creative Museum Designers</b>			
UNIT: Design Section		PROJ: GSI Gwalior Gallery - II	
DRG.NO. CMD-007.12.52.1/EN-7/2	DATE 01/08/2023	SCALE NTS	TOLERANCE
TITLE EX- 7.3			NO OFF 01 OFF 03
Drawn By Mr. Pratik Saha	Checked By Mr. Susanta Shaw	Approved By Mr. K. S. Murali	

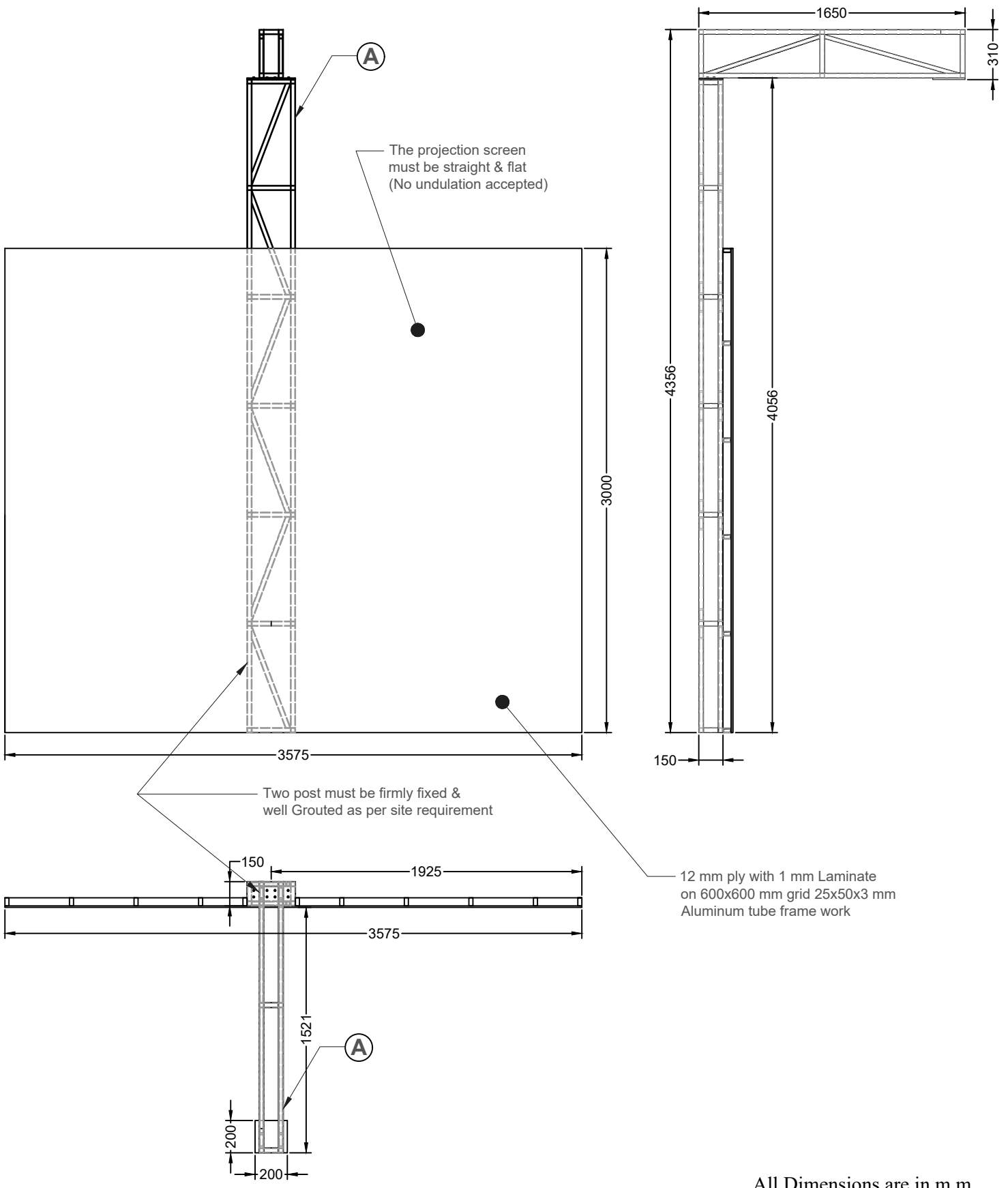

All Dimensions are in m.m.

<b>Creative Museum Designers</b>				
UNIT: Design Section		PROJ: GSI Gwalior Gallery - II		
DRG.NO. CMD-007.12.52.1/EN-7/2	DATE 01/08/2023	SCALE NTS	TOLERANCE	
TITLE Ex - 7.3			NO OFF 02 OFF 03	
Drawn By Mr. Pratik Saha	Checked By Mr. Susanta Shaw	Approved By Mr. K. S. Murali		

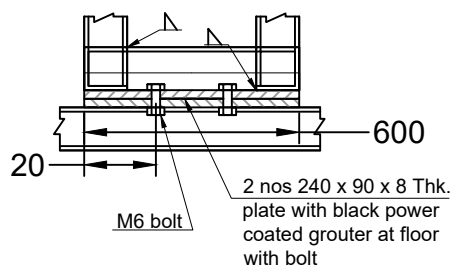
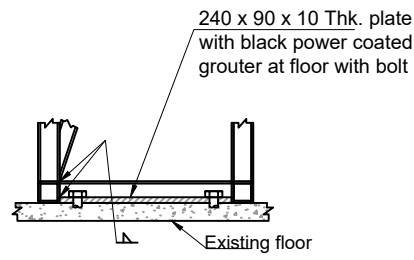
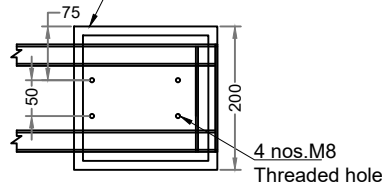
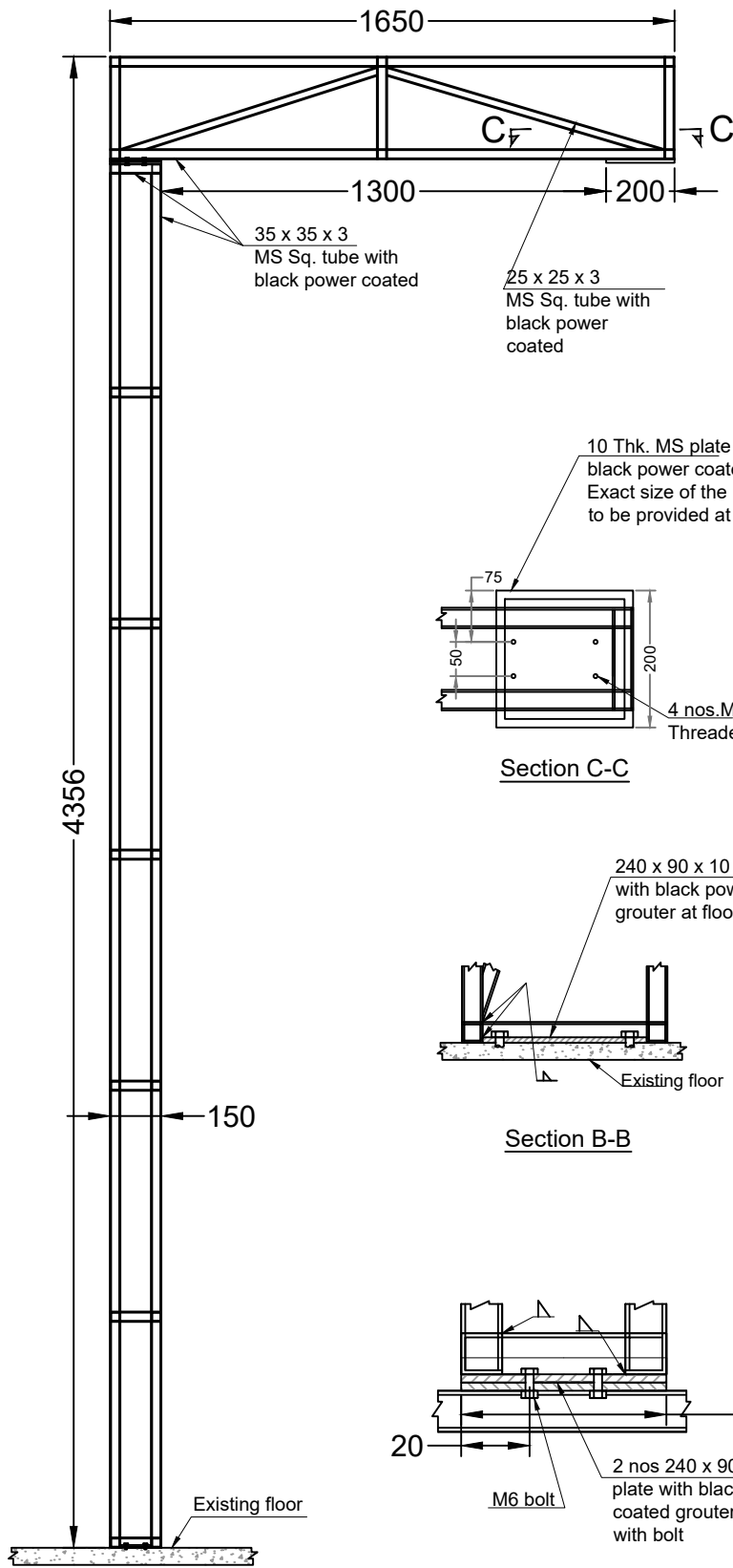

Section A-A

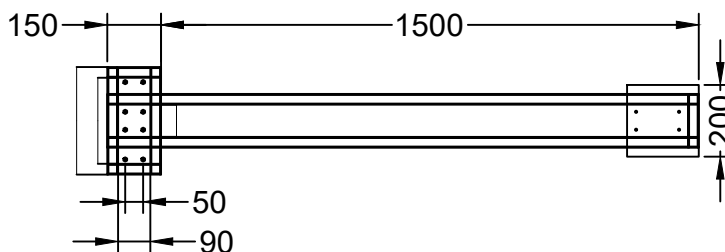
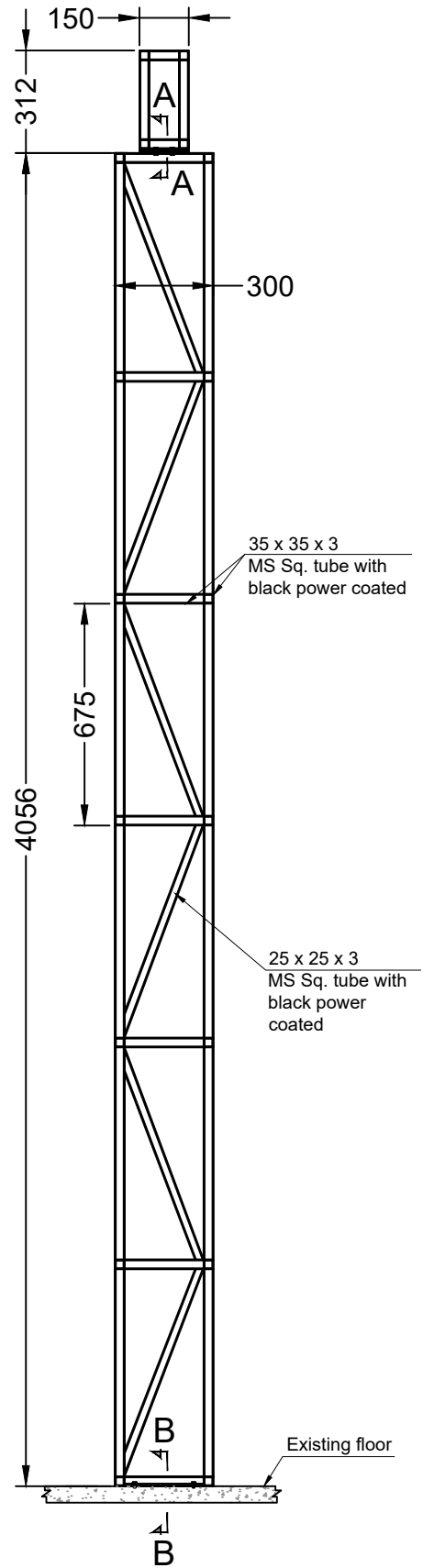

All Dimensions are in m.m.

<b>Creative Museum Designers</b>			
UNIT: Design Section	PROJ: GSI Gwalior Gallery - II		
DRG.NO. CMD-007.12.52.1/EN-7/2	DATE 01/08/2023	SCALE NTS	TOLERANCE
TITLE Ex - 7.3		NO OFF 03 OFF 03	
Drawn By Mr. Pratik Saha	Checked By Mr. Susanta Shaw	Approved By Mr. K. S. Murali	

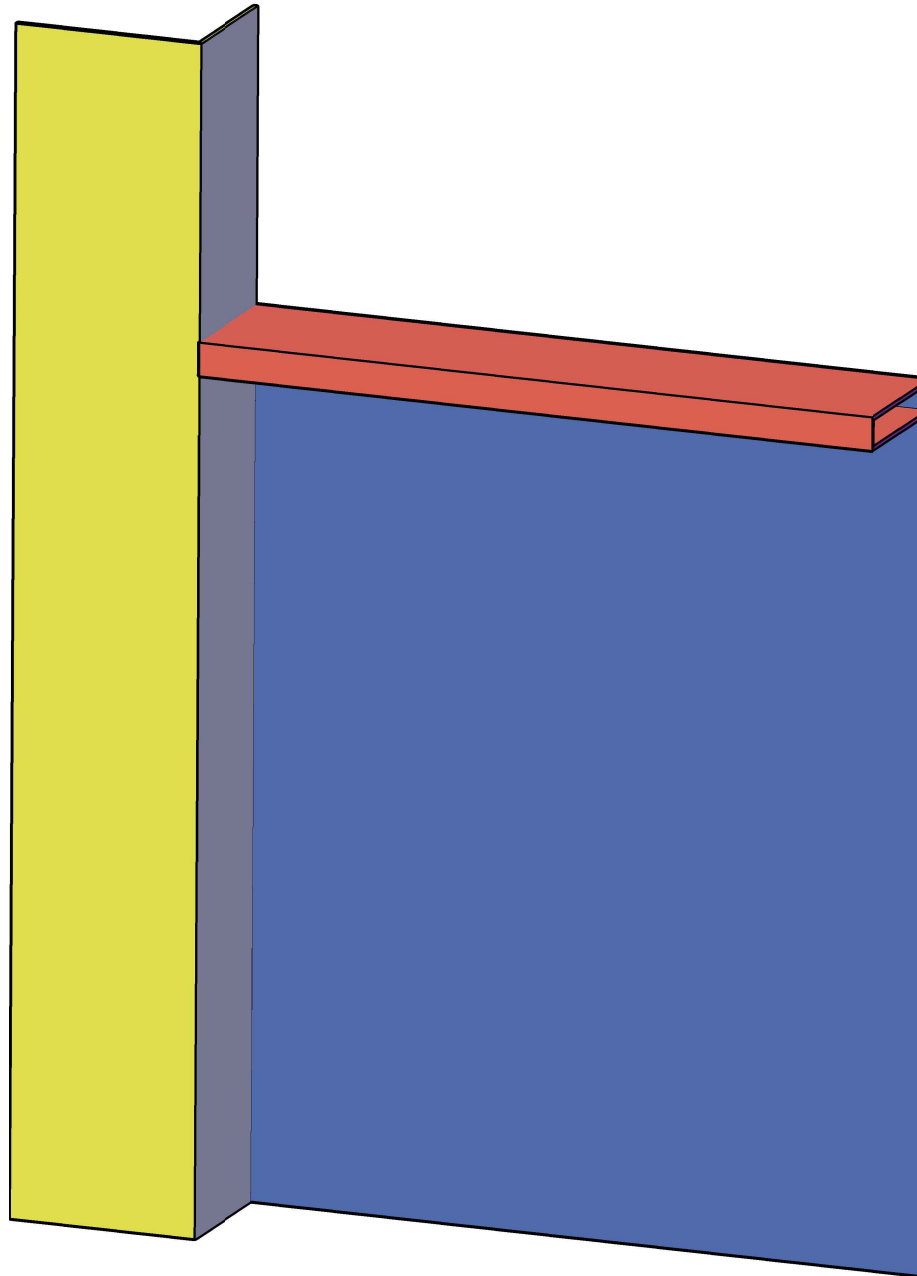

All Dimensions are in m.m.

<b>Creative Museum Designers</b>			
UNIT: Design Section		PROJ: GSI Gwalior Gallery - II	
DRG.NO. CMD-007.12.52.1/EN-7/3	DATE 01/08/2023	SCALE NTS	TOLERANCE
TITLE EX- 7.5			NO OFF 01 OFF 02
Drawn By Mr. Pratik Saha	Checked By Mr. Susanta Shaw	Approved By Mr. K. S. Murali	

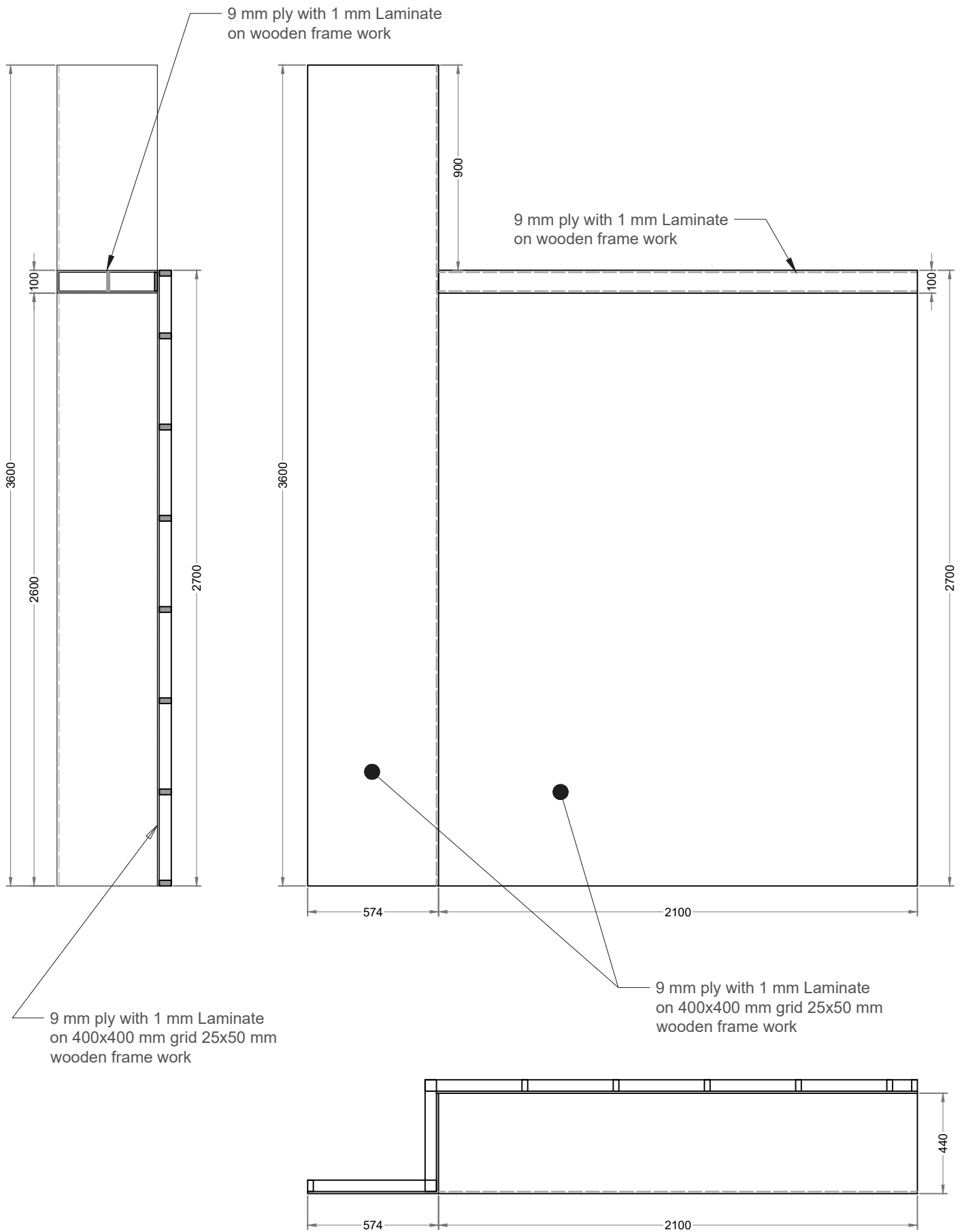

All Dimensions are in m.m.

<b>Creative Museum Designers</b> 			
UNIT: Design Section	PROJ: GSI Gwalior Gallery - II		
DRG.NO. CMD-007.12.52.1/EN-7/3	DATE 01/08/2023	SCALE NTS	TOLERANCE
TITLE Ex - 7.5			NO OFF 02 OFF 02
Drawn By Mr. Pratik Saha	Checked By Mr. Susanta Shaw	Approved By Mr. K. S. Murali	



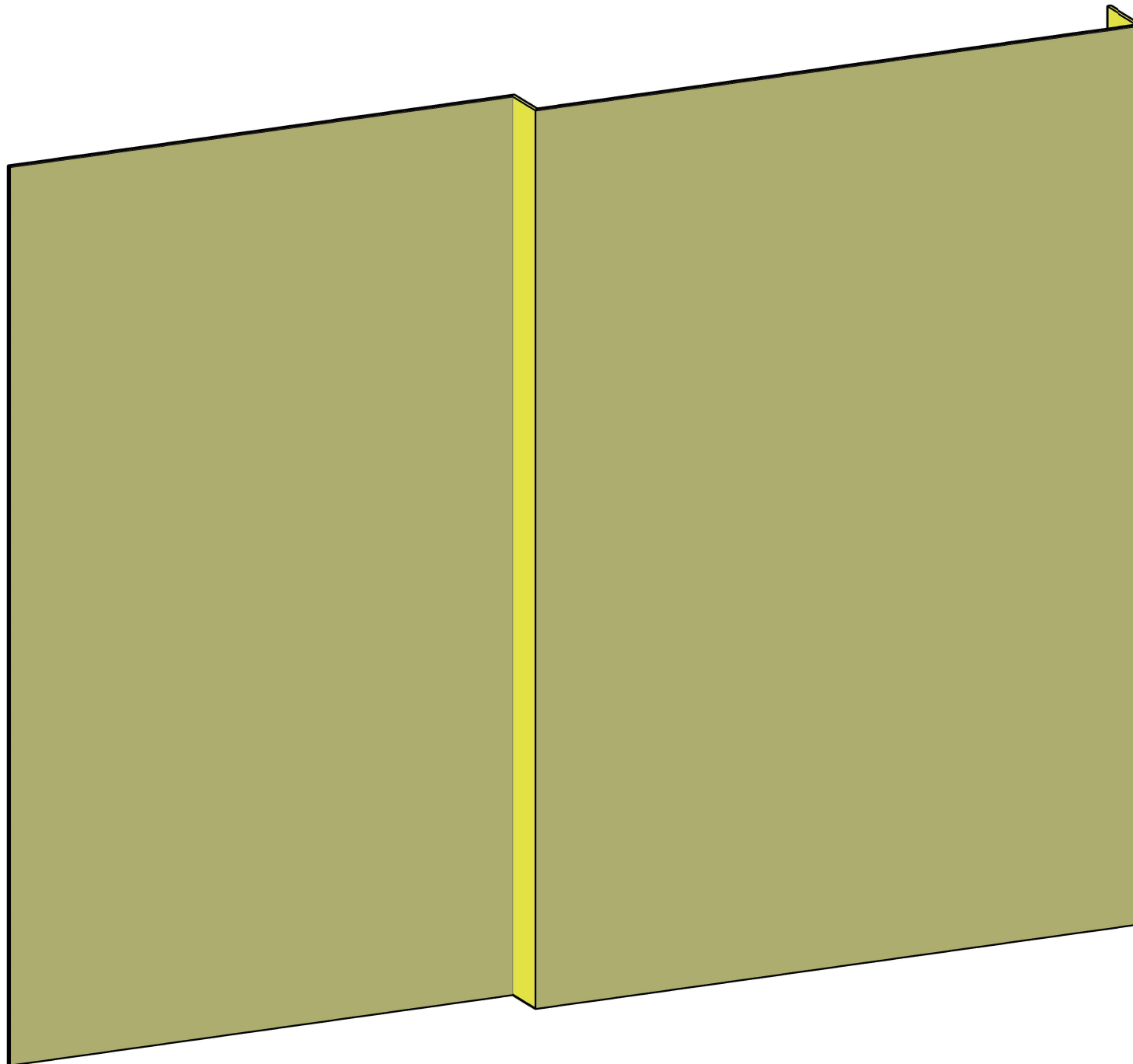

All Dimensions are in m.m.

<b>Creative Museum Designers</b>			
UNIT: Design Section		PROJ: GSI Gwalior Gallery - II	
DRG.NO. CMD-007.12.52.1/EN-7/4	DATE 01/08/2023	SCALE NTS	TOLERANCE
TITLE Ex- 7.7, Ex- 7.8			NO OFF 01 OFF 02
Drawn By Mr. Pratik Saha	Checked By Mr. Susanta Shaw	Approved By Mr. K. S. Murali	

9 mm ply with 1 mm Laminate  
on 400x400 mm grid 25x50 mm  
wooden frame work

9 mm ply with 1 mm Laminate  
on 400x400 mm grid 25x50 mm  
wooden frame work

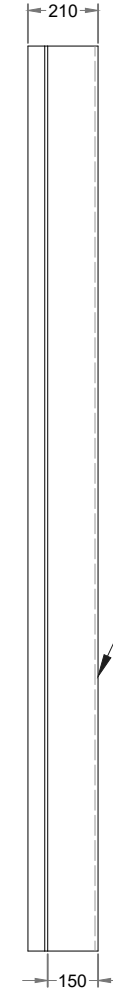
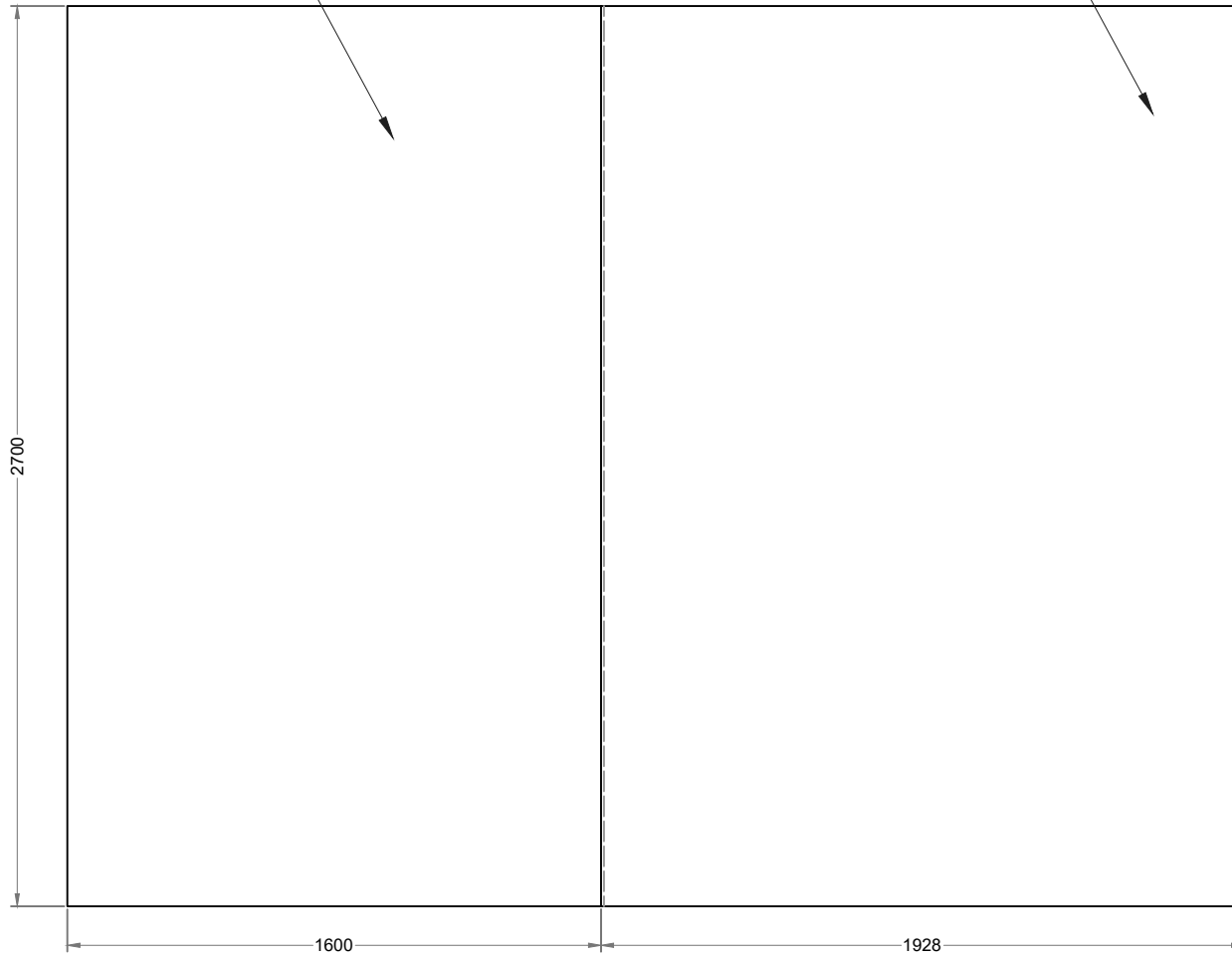

9 mm ply with 1 mm Laminate  
on 400x400 mm grid 25x50 mm  
wooden frame work

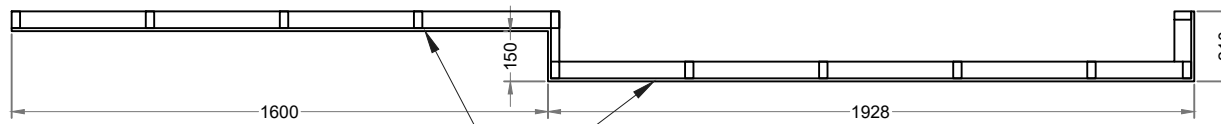

9 mm ply with 1 mm Laminate  
on 400x400 mm grid 25x50 mm  
wooden frame work

All Dimensions are in m.m.

<b>Creative Museum Designers</b> 			
UNIT: Design Section	PROJ: GSI Gwalior Gallery - II		
DRG.NO. CMD-007.12.52.1/EN-7/4	DATE 01/08/2023	SCALE NTS	TOLERANCE 02 OFF 02
TITLE Ex - 7.7 , Ex -7.8			NO OFF 02 OFF 02
Drawn By Mr. Pratik Saha	Checked By Mr. Susanta Shaw	Approved By Mr. K. S. Murali	